



OZ OPTICS LTD.

APPLICATION NOTE

DD-100

OZ OPTICS FAMILY OF OEM MOTOR DRIVEN ATTENUATORS

The information/data furnished in this document shall not be duplicated, used or disclosed in whole or in part for any purpose other than to which it was intended.

CONTENTS

Introduction	3
Applications	3
Theory of Operation.....	3
Sample Applications	5
DD-100 (Basic Model).....	7
DD-100 (-DR Option)	10
DD-100 (-MC Option).....	15
RS-232/SPI/I ² C Command Set.....	19
RS-232 Additional Commands	19
SPI Protocol	20
SPI Timing Specifications	20
Mechanical Dimensions	21
Ordering Information.....	22

INTRODUCTION

The OZ Optics family of Motor Driven attenuators satisfies the needs of the OEM marketplace.

For applications where a small compact OEM version of our Motor Driven attenuator is required, OZ offers the DD-100. The DD-100 comes in three versions depending on the level of support circuitry the client wishes to engage in; DD-100 (basic); DD-100,-DR; DD-100,-MC. The DD-100 (basic) version provides the user with a direct connection to the stepper motor windings. A logic level output is provided for HOME position information. The HOME signal tells the user when the stepper motor has stepped to a specified, pre-determined location as set by the factory. This position, in-turn, allows the user to calibrate the DD-100 in terms of optical attenuation versus steps from HOME. The DD-100,-DR includes a stepper motor drive circuit using an H-Bridge Chopper configuration. The user drives 4 TTL logic level inputs representing the phase information to the driver circuit which in turn drives the stepper motor windings. Finally, the DD-100,-MC offers an embedded microController so as to enable the user to simply transmit position or attenuation commands directly to the attenuator via a serial interface.

This device has been manufactured in two connector configurations: a 20 pin version (being phased-out), and a 16 pin version.

This Application Note applies to both versions of the device, which are functionally identical.

APPLICATIONS

- Bit Error Rate (BER) testing.
- Simulating Optical Link Budgets.
- Designing Optical receiver Front-ends.
- Power Meter Linearity measurements.
- Power setting.
- Active gain equalization in dense WDM systems.

THEORY OF OPERATION

The working principle behind the family of Motor Driven attenuators is quite simple. Depending on whether a singlemode or multimode attenuator is required, a blocking type or neutral density filter type device is used.

Blocking Type Attenuator

In the blocking type attenuator used in singlemode applications, light from the source fiber is collimated into a beam approximately 0.4mm – 0.6mm wide (for wavelengths 458nm-1550nm). A blocking device is then inserted into the beam of collimated light in varying degrees depending on the attenuation required. A precision stepper motor through a reduction gear assembly controls the blocking device. (See Figure 1)

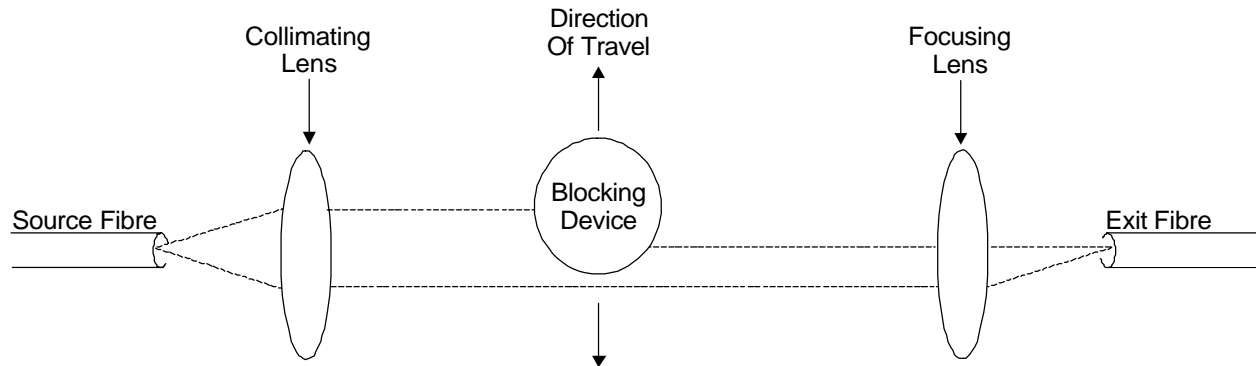

FIGURE 1

This technique allows for high speed, high-resolution attenuation under digital stepper motor control.

Neutral Density Filter Type Attenuator

In the neutral density filter type attenuator used for multimode applications, light is again collimated into a beam. A neutral density filter whose attenuation varies from 0.5 dB to over 30 dB is then inserted into the collimated light. The position of the filter within the beam determines the attenuation experienced. The filter is controlled using a leaf spring loaded cam system connected to a precision stepper motor through a gear reduction assembly (See Figure 2).

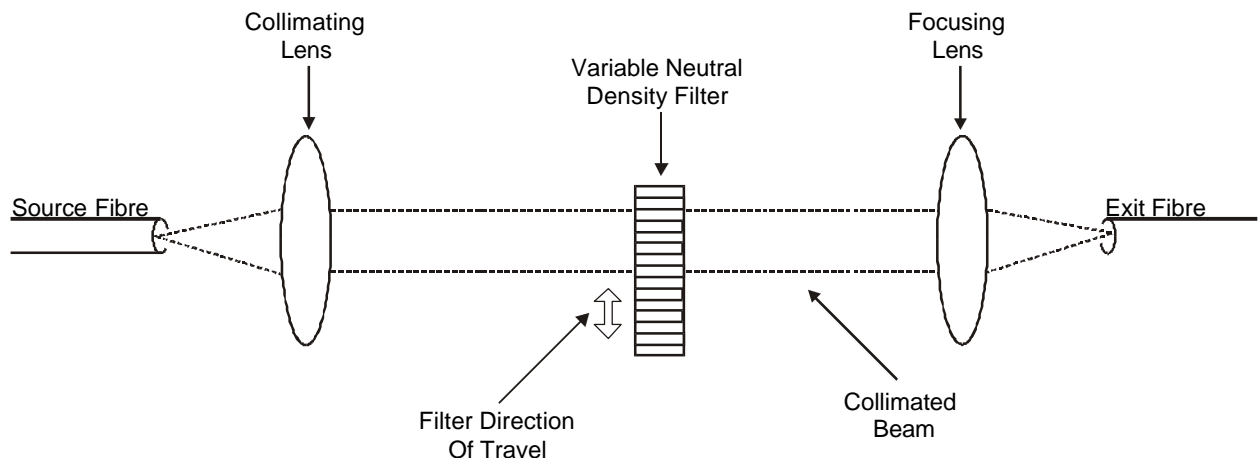

FIGURE 2

SAMPLE APPLICATIONS

Sample Application #1

Signal Strength Monitoring And Control System

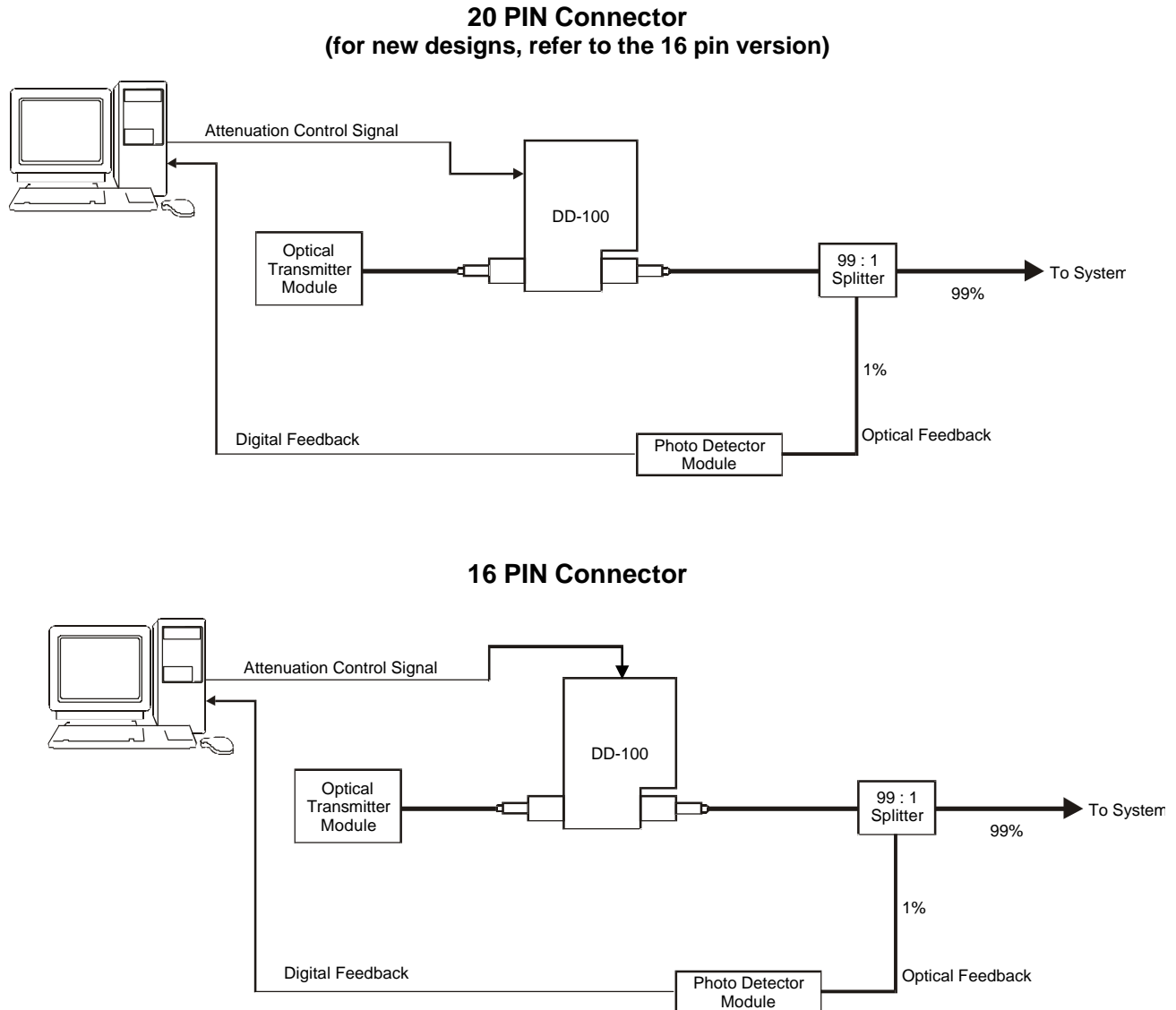

FIGURE 3

As illustrated in Figure 3 above, light from a transmission module is sent through a DD style attenuator before entering the transmission line. A 99:1 splitter is used to tap off a small monitor signal. This signal is measured with a photodiode module, which produces a digital representation of the light intensity. Based on this feedback, the computer adjusts the attenuator to set the output signal at the optimum intensity.

Sample Application #2

Load Balancing On A WDM System

20 PIN Connector

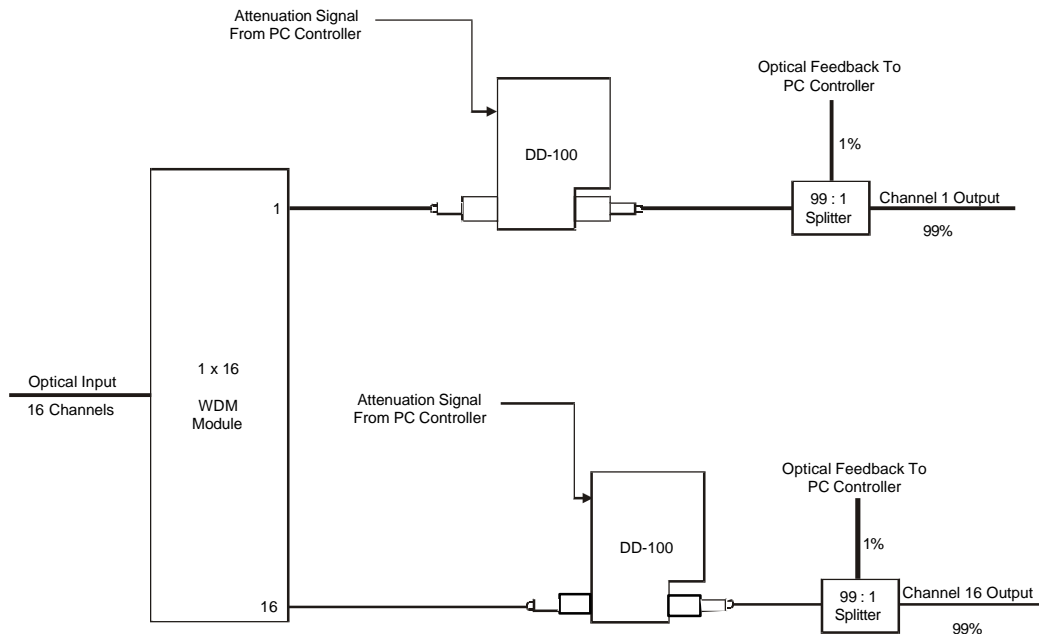

16 PIN Connector

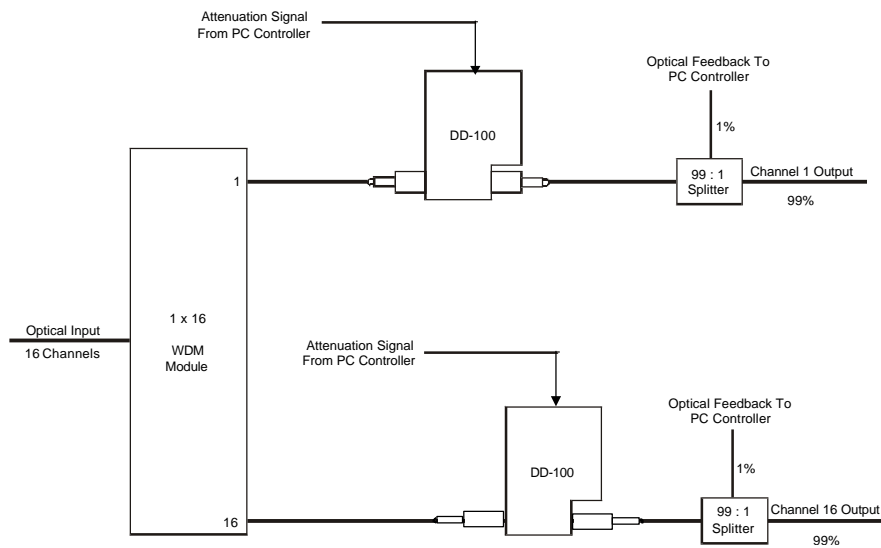

FIGURE 4

Multiplexed light from a trunk line is demultiplexed into individual signals as shown in Figure 4. They are of different intensities. The signals have to be balanced to avoid saturating any of the receivers. DD style attenuators are inserted between the WDM and the receiver modules. Whenever a receiver module is saturated, a signal is sent to the control computer to increase the attenuation to that module. Whenever the signal becomes too low, the control computer decreases the attenuation.

DD-100 (BASIC MODEL)

This basic version of the OEM Motor Driven Attenuator provides the Motor Driven assembly and pigtailed optics in the active attenuation block. The built-in connector provides direct electrical connection to the motor windings. A mounted LED and photodiode on the attenuation block provides a means of HOME sensing. The feedback from the photodiode is also provided at the DD-100 connector for use by external circuitry.

The pin-out of the 20 pin version DD-100 connector is outlined in Figure 5:

<u>Pin #</u>	<u>Pin Design</u>	<u>Comments</u>
20	Motor A1	Motor Coil "A" Lead 1
19	(factory use only)	DO NOT CONNECT
18	Motor A2	Motor Coil "A" Lead 2
17	(factory use only)	DO NOT CONNECT
16	Motor B1	Motor Coil "B" Lead 1
15	(factory use only)	DO NOT CONNECT
14	Motor B2	Motor Coil "B" Lead 2
13	(factory use only)	DO NOT CONNECT
12	N/C	DO NOT CONNECT
11	N/C	DO NOT CONNECT
10	Home Output	TTL output. High level indicates HOME position
9	N/C	DO NOT CONNECT
8	(factory use only)	DO NOT CONNECT
7	(factory use only)	DO NOT CONNECT
6	(factory use only)	DO NOT CONNECT
5	(factory use only)	DO NOT CONNECT
4	+5VDC	Logic Supply Voltage
3	+5VDC	Logic Supply Voltage
2	GND	Common ground
1	GND	Common ground

FIGURE 5
(For new designs, refer to the 16 pin connector version)

The physical connector pin-out orientation of the 20 pin version is shown in Figure 6 below, (facing the connector with the fiber to the right):

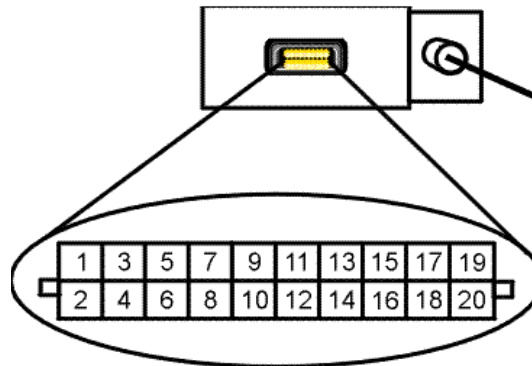

FIGURE 6

The pin-out of the 16 pin version DD-100 connector is outlined in Figure 7:

<u>Pin #</u>	<u>Pin Design</u>	<u>Comments</u>
16	B1	Motor Coil "B" Lead 1
15	B2	Motor Coil "B" Lead 2
14	A1	Motor Coil "A" Lead 1
13	A2	Motor Coil "A" Lead 2
12	Factory Use Only	DO NOT CONNECT
11	Factory Use Only	DO NOT CONNECT
10	Home Output	TTL output. High level indicates HOME position
9	Factory Use Only	DO NOT CONNECT
8	Factory Use Only	DO NOT CONNECT
7	Factory Use Only	DO NOT CONNECT
6	Factory Use Only	DO NOT CONNECT
5	Factory Use Only	DO NOT CONNECT
4	Factory Use Only	DO NOT CONNECT
3	+5VDC	Logic Supply Voltage
2	GND	Common ground
1	GND	Common Ground

FIGURE 7

The physical connector pin-out orientation of the 16 pin version is shown in Figure 8 below, (facing the connector):

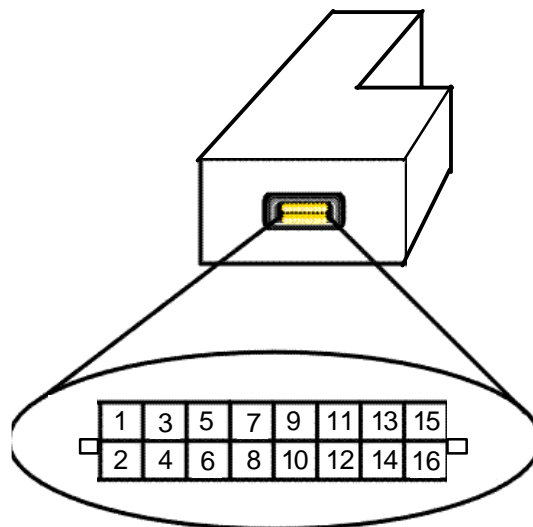

FIGURE 8

The electrical specifications for each of these three voltage types of stepper motors available in the DD-100 family are shown in Figure 9. These specifications are valid for connector pins 13 through 20 on the 20 pin connector as provided in Figure 6. These specifications are also valid for pins 13 through 16 on the 16 pin connector as provided in Figure 8.

Electrical Specifications

For Motor Type AM 1524	Voltage Mode		
	V-6-35	V-12-150	V-24-590
Phase Resistance (Ohms)	35	150	590
Phase Inductance (1kHz) mH	15	65	239
Nominal Current A/Ph (2 ph on)	0.15/6V	0.075/12V	0.037/24V
Nominal Current A/Ph (1 ph on)	0.20/8V	0.100/15V	0.052/34V
Back EMF Amplitude V/K steps/second	6	12	24
Dielectric Test (1 min)	500 Vrms All Types		
Electrical Time Constant (ms)	0.4 ms All Types		

FIGURE 9

Typical DD-100 Use:

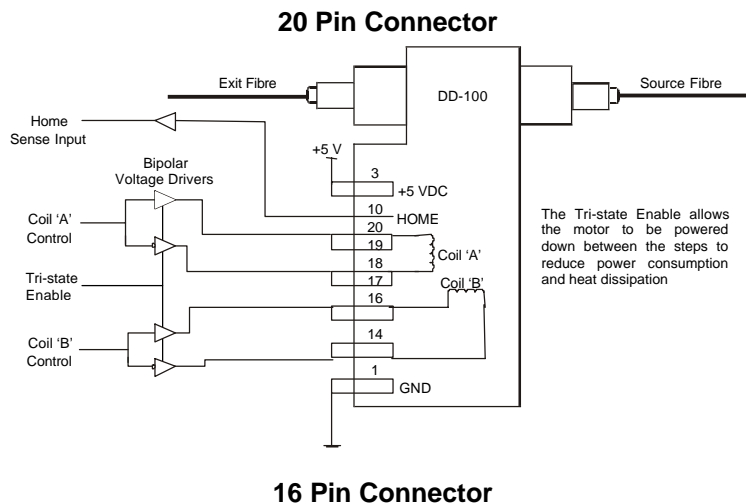

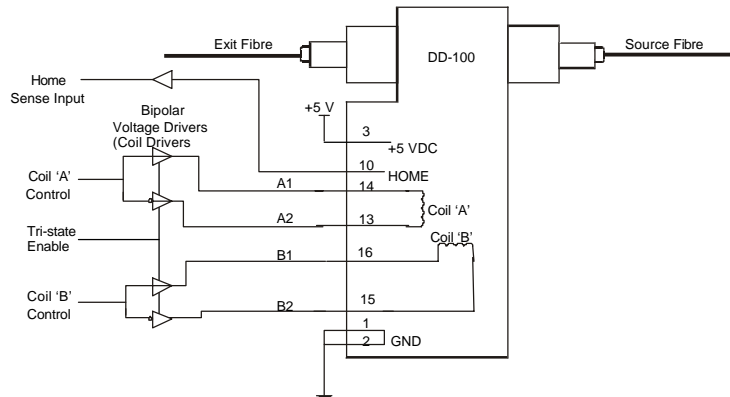

FIGURE 10

DD-100 (-DR OPTION)

By designating the suffix “-DR” as part of the part number, the DD-100 will have a built-in Stepper Motor Driver circuit. The driver circuit is an HBridge type circuit which alternates the polarity of the voltage across the motor windings based on logic levels inputs. This fully integrated product has the same dimensions as the DD-100. The optical feedback for “HOME” position sensing is also provided.

The pin-out for the 20 pin DD-100, -DR is provided in Figure 11:

<u>Pin #</u>	<u>Pin Design</u>	<u>Comments</u>
20	(factory use only)	DO NOT CONNECT
19	D Input	Motor Coil “D” TTL Input
18	(factory use only)	DO NOT CONNECT
17	C Input	Motor Coil “C” TTL Input
16	(factory use only)	DO NOT CONNECT
15	B Input	Motor Coil “B” TTL Input
14	(factory use only)	DO NOT CONNECT
13	A Input	Motor Coil “A” TTL Input
12	N/C	DO NOT CONNECT
11	N/C	DO NOT CONNECT
10	N/C	DO NOT CONNECT
9	Home Output	TTL output. High level indicates HOME position
8	(factory use only)	DO NOT CONNECT
7	(factory use only)	DO NOT CONNECT
6	Motor Drive	Motor Supply Voltage
5	Motor Drive	Motor Supply Voltage
4	+5VDC	Logic Supply Voltage
3	+5VDC	Logic Supply Voltage
2	GND	Common ground
1	GND	Common ground

FIGURE 11

The physical connector orientation is the same as shown in Figure 6.
For new designs, use the 16 pin version.

The pin-out for the 16 pin DD-100, -DR is provided in Figure 12:

Pin #	Pin Design	Comments
16	C Input	Motor Coil "C" TTL Input
15	D Input	Motor Coil "D" TTL Input
14	A Input	Motor Coil "A" TTL Input
13	B Input	Motor Coil "B" TTL Input
12	(factory use only)	DO NOT CONNECT
11	(factory use only)	DO NOT CONNECT
10	Home Output	TTL Output. High level indicates HOME position
9	(factory use only)	DO NOT CONNECT
8	(factory use only)	DO NOT CONNECT
7	(factory use only)	DO NOT CONNECT
6	+ V	Motor Supply Voltage
5	+ V	Motor Supply Voltage
4	(factory use only)	DO NOT CONNECT
3	+5VDC	Logic Supply Voltage
2	GND	Common ground
1	GND	Common ground

FIGURE 12

The physical connector orientation is the same as shown in Figure 8.

Electrical Specifications DD-100-DR

All signals are TTL levels except for the power and ground signals on pins 1 through 6 for both the 20 pin connector and the 16 pin connector.

Typical DD-100, -DR Use:

20 Pin Connector Version

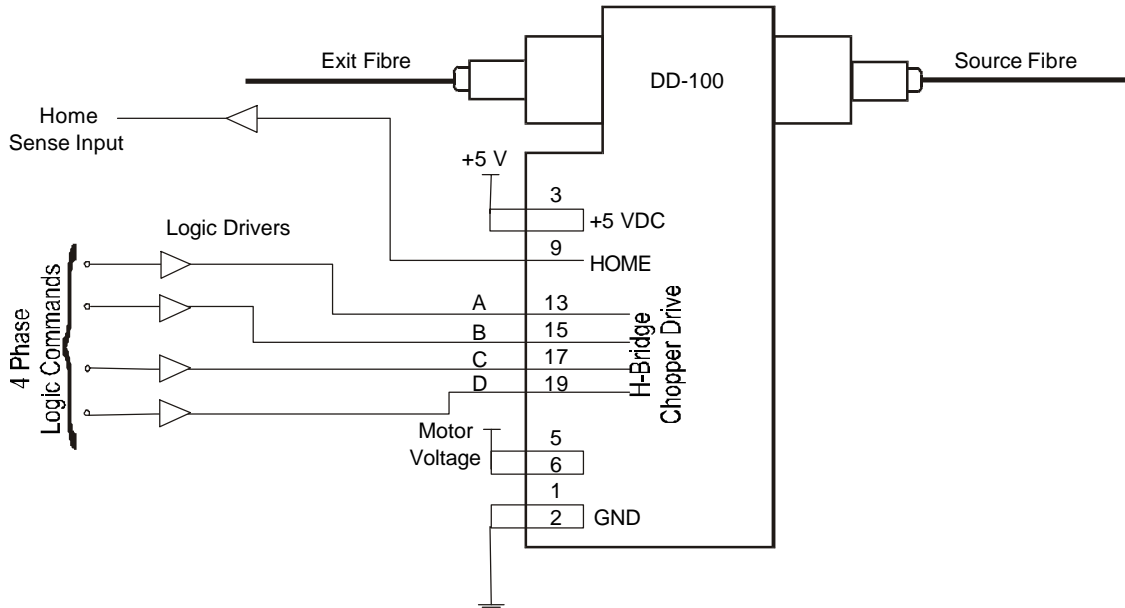

16 Pin Connector Version

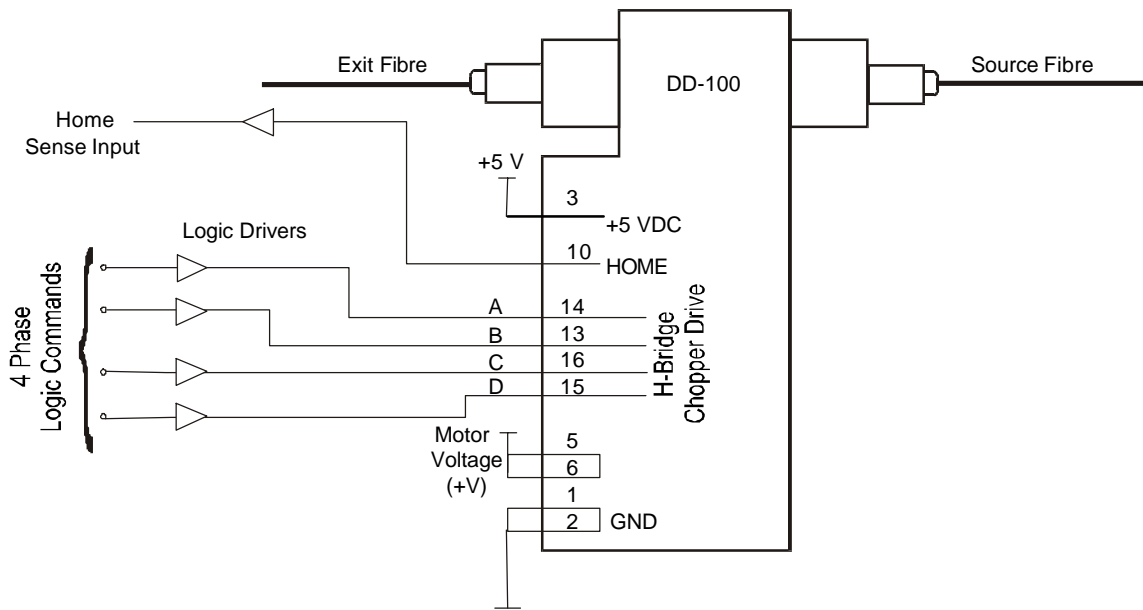
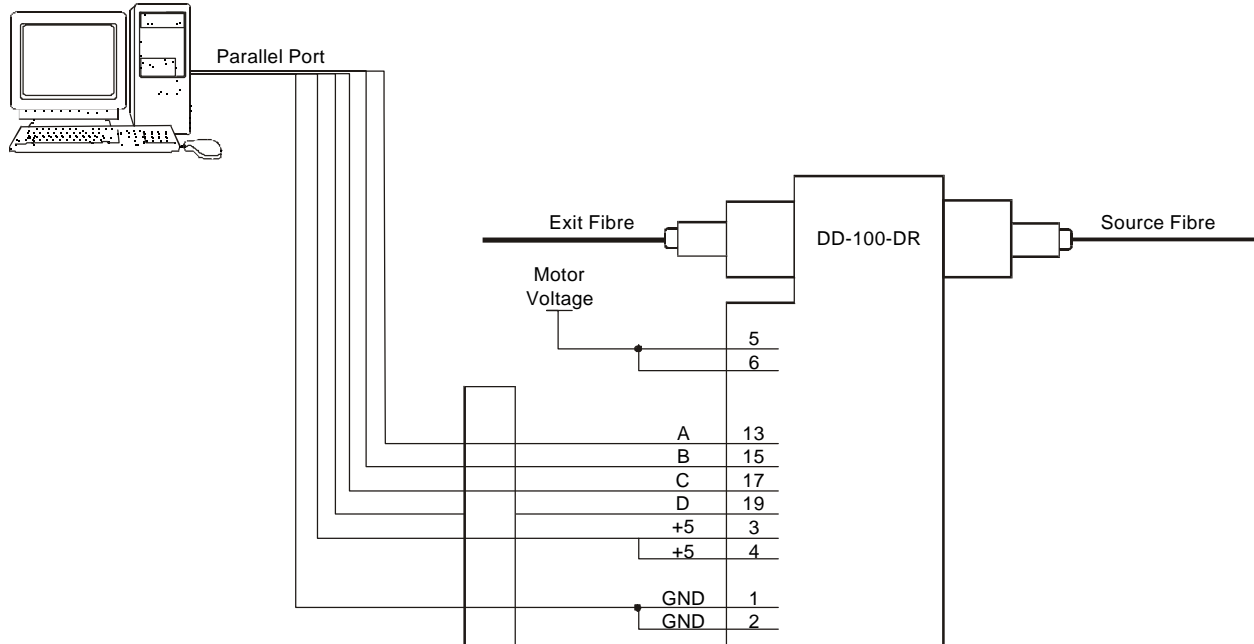

FIGURE 13

Another method of use for the DD-100 -DR is by connecting it to the parallel port of the PC as shown in Figure 14 below. This method allows the user to drive the attenuator directly from a PC. The user must ensure that proper timing sequences are honored as per Figure 15.

20 Pin Connector Version



16 Pin Connector Version

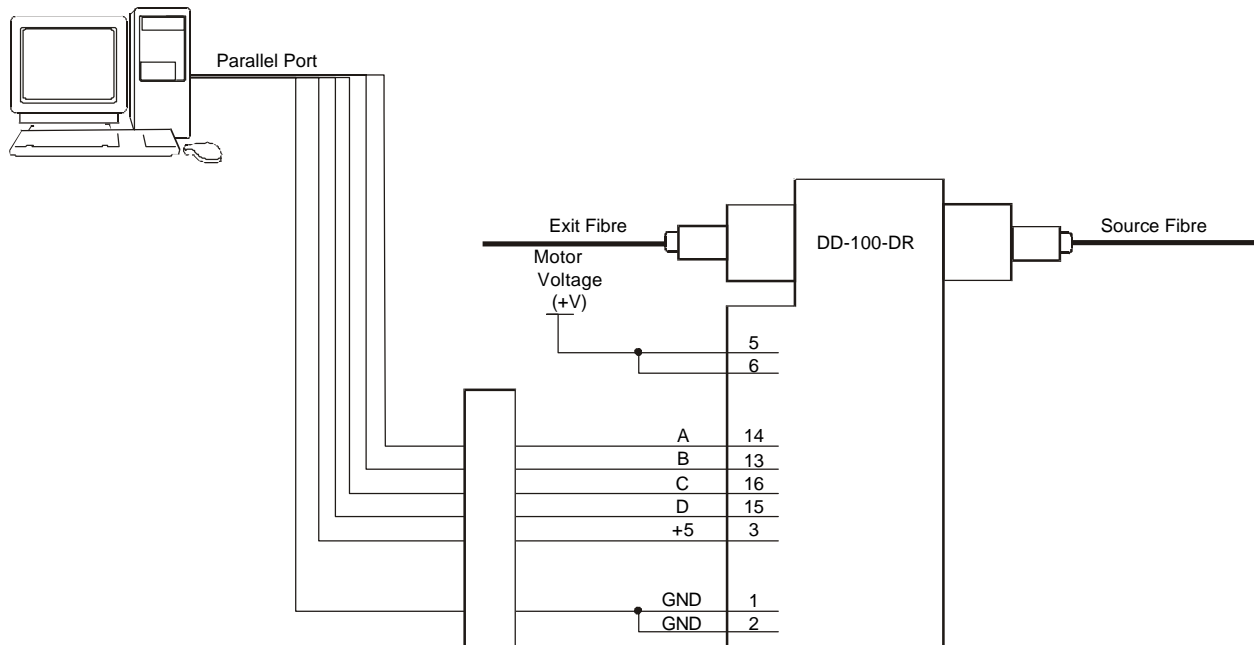
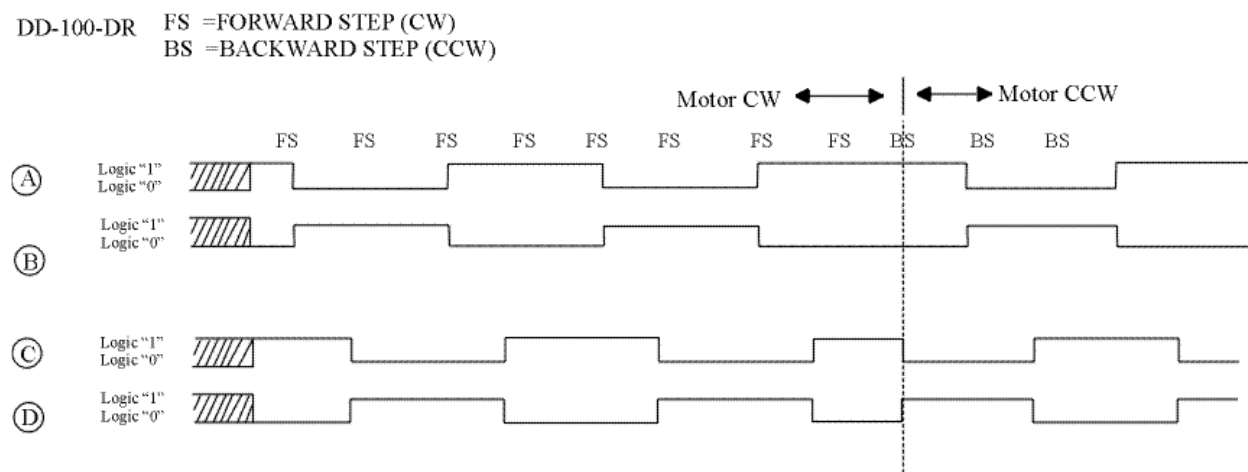

FIGURE 14

Stepper Motor Input Timing

Whether the DD-100 basic unit or the DD-100(-DR) unit is used, the timing of the stepper motor signals is the same. The only difference is that the DD-100 basic unit requires analog drive voltages to the motor coils directly whereas the -DR version only requires TTL input signals. The timing is illustrated in Figure 15 below. Note that forward and reverse movement is accomplished by reversing the timing at any point.



If A and B are at the same logic levels, and C and D are at the same logic levels, then the attenuator will enter a low power mode. (See Below).

DD-100

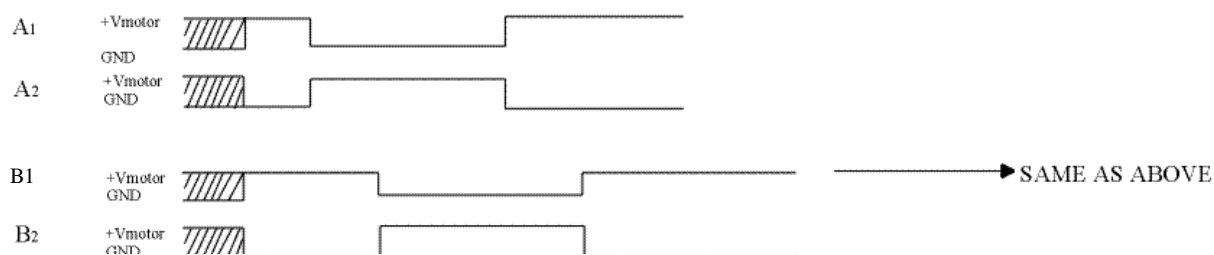

FIGURE 15

NOTE:

If A1 and A2 are at the same voltage, and B1 and B2 are at the same voltage, then the attenuator will enter a low power mode. In the low power mode no current flows through the motor coils. This will minimize power consumption and limit the attenuation drift caused by heating of the optical components. A delay of at least 0.1 seconds must be allowed after stepping before entering the low power mode. While in the low power mode, the position of the motor will be maintained.

When exiting the low power mode, the drive signals must be restored to exactly the same as they were prior to entering the low power mode, for at least 0.1 seconds before further stepping takes place.

DD-100, (-MC OPTION)

For those applications where the user would simply like to give the DD-100 optical attenuation commands, OZ Optics provides a built-in microcontroller. This OEM version of the DD-100 is designated by the suffix “-MC” in the product part number. Communication to the attenuator is via an RS232, SPI or I²C interface.

The pin-out for the 20 pin version of the DD-100, -MC is provided in Figure 16:

Pin #	Pin Design	Comments
20	(factory use only)	DO NOT CONNECT
19	(factory use only)	DO NOT CONNECT
18	(factory use only)	DO NOT CONNECT
17	(factory use only)	DO NOT CONNECT
16	(factory use only)	DO NOT CONNECT
15	(factory use only)	DO NOT CONNECT
14	(factory use only)	DO NOT CONNECT
13	(factory use only)	DO NOT CONNECT
12	SDO	SPI data output
11	SDI/SDA	SPI data in / I ² C data
10	SCK/SCL	SPI clock / I ² C clock
9	ENABLE	Device Enable (active low TTL input)
8	RX	RS-232 receiver input
7	TX	RS-232 transmitter output
6	+V	Supply Voltage for motor
5	+V	Supply Voltage for motor
4	+5VDC	Logic Supply Voltage
3	+5VDC	Logic Supply Voltage
2	GND	Common ground
1	GND	Common ground

FIGURE 16

The physical connector orientation is the same as shown in Figure 6.
For new designs, refer to the 16 pin connector version.

The pin-out for the 16 pin version of the DD-100, -MC is provided in Figure 17:

Pin #	Pin Design	Comments
16	(factory use only)	DO NOT CONNECT
15	(factory use only)	DO NOT CONNECT
14	(factory use only)	DO NOT CONNECT
13	(factory use only)	DO NOT CONNECT
12	SDI / SDA	SPI data In / I ² C Data
11	SDO	SPI data out
10	Enable	SPI Enable (Active low TTL input)
9	SCK / SCL	SPI Clock / I ² C clock
8	TX	RS-232 transmitter output
7	RX	RS-232 receives input
6	+ V	Supply Voltage for motor
5	+ V	Supply Voltage for motor
4	V bat	Battery Back up for memory (optional)
3	+5VDC	Logic Supply Voltage
2	GND	Common ground
1	GND	Common ground

FIGURE 17

The physical connector orientation is the same as shown in Figure 8.

Electrical Specifications for DD-100-MC

The following values apply with a logic supply of VDD=5 volts, at 22°C unless otherwise noted.

		Min	Typical	Max	Units
Logic supply	(VDD)	4.5		5.5	volts
Input low(1)	(VIL)	0		0.8	volts
Input high(1)	(VIH)	2.0		VDD	volts
Output Low(2)	(VOL)	0		0.6	volts IOL=8.5MA
Output high(2)	(VOH)	VDD-0.7	4.5	VDD	volts
Motor voltage(3)	6 volt version	5	6	12.25	volts
	12 volt version	10	12	12.25	volts
RS232 Input		-25		25	volts
RS232 Output			-5/+5		volts
Battery voltage(4)	(Vbat)	3	5	5.5	volts

(1) SDI/SDA, SCK/SCL, ENABLE

(2) SPI data out, SDA

(3) The unit will automatically detect the operating voltage and configure itself accordingly. For voltages in the range of 5 to 7.8 volts, the unit will operate in "voltage" mode. For voltages above 10 volts, the unit will operate in the faster "current" mode. If high speed is required, supply 12 volts for the motor drive.

Warning: Motor voltages above 12.25 volts may damage the control circuitry. Do not exceed this limit.

The motor voltage must not be applied in the absence of the logic supply voltage. The motor supply may be turned on or off at the same time as the logic supply.

(4) Vbat should not exceed the logic supply voltage during normal operation. Vbat allows the device to retain position information and settings, even when the main logic and motor supplies are absent. It does not allow full functionality of the unit in the absence of the other power supplies. When the logic supply and motor supplies are restored, normal operation may resume. Power from Vbat will be drawn when the logic supply voltage falls below the voltage level of Vbat.

Typical DD-100, -MC Use

20 Pin Connector Version

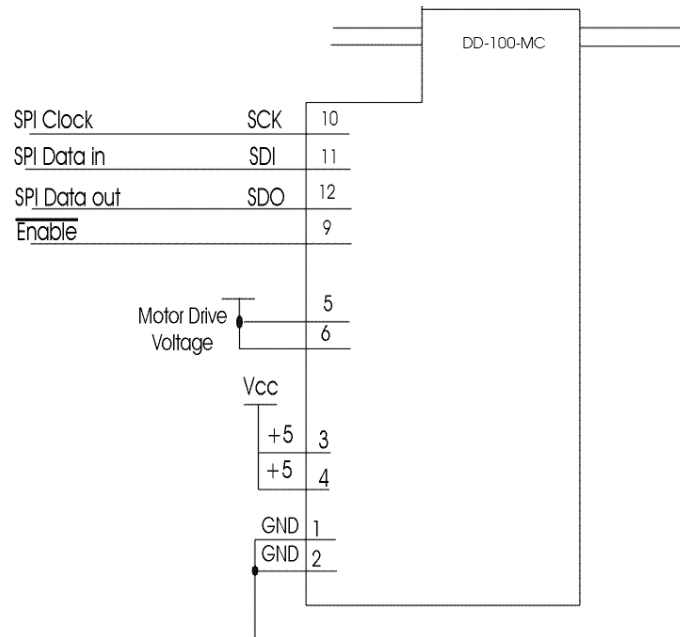

16 Pin Connector Version

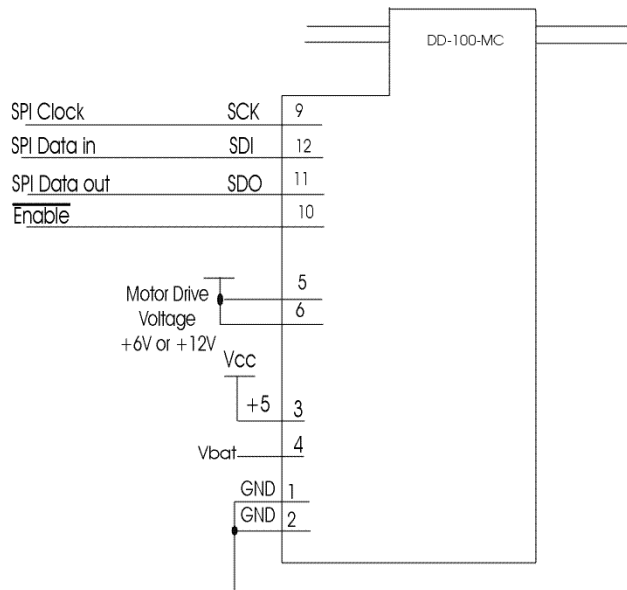

FIGURE 18

Note that the user must specify the communication mode they would like when ordering the product.

- SPI for SPI mode
- IIC for I²C mode
- RS232 for RS-232 mode

Typical DD-100-MC Application

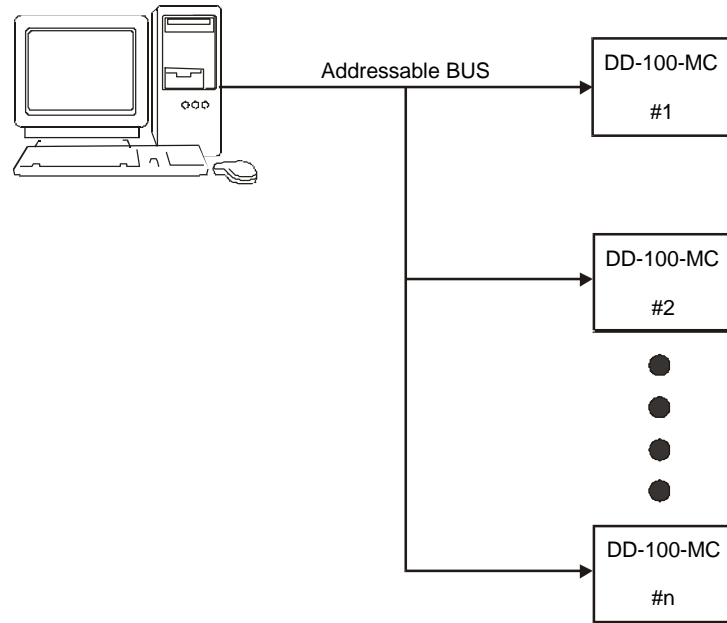

Figure 19

RS-232 / SPI / I²C COMMAND SET

NOTE: [CR] is a Carriage Return. Most commands do not require a Carriage Return.

- A <n> [CR] Set attenuation to <n>.
Example: A23.54 (CR)
Sets the attenuation to 23.54 dB.
- B Steps the attenuator one step backward.
- CD Sends the current DD-100-MC configuration to the RS232 output. This command outputs on the RS232 transmit line in all modes.
- CS<n1><n2> Set the SPI clock polarity and clock edge select.
n1 = 1 {Sets idle state for clock to a high level.
n2 = 1 Data is transmitted on falling edge of SCL.
n2 = 0 Data is transmitted on rising edge of SCL.}
n1 = 0 {Sets idle state for clock to a low level.
n2 = 1 Data is transmitted on rising edge of SCL.
n2 = 0 Data is transmitted on falling edge of SCL.}
- F Steps the attenuator one step forward.
- H Rehomes the unit.
- R Requests the status of the attenuator. (Available for software revisions 2.21 and later). In RS232 mode, the attenuator returns “done” when no other operations are pending. It will not respond to this command while it is busy doing other things. In the SPI mode, the attenuator will return the number “0” when it is idle. Nothing will be returned while it is busy executing previous commands.
- S <n> [CR] Set steps from HOME position to <n>.
Example: S584 (CR)
Sets the number of steps from HOME position to 584.
- W<n> Switches between available wavelengths. <n> can be 1 or 2. If two calibrated wavelengths are to be used, they must be specified at the time of ordering the attenuator.

Note: All RS232 commands are in 8 – bit ASCII format, with one stop bit, no parity, and a data rate of 9600 baud.

RS-232 ADDITIONAL COMMANDS

- D Outputs the current attenuation and related steps from HOME.

For more complete information on the command set, refer to the DD-100-MC Operating Instructions manual.

Note: WHEN THE UNIT IS FIRST POWERED UP IT WILL RESPOND ONLY TO THE HOME COMMAND. THIS IS REQUIRED TO ENSURE THAT THE MOTOR IS IN A KNOWN POSITION.

SPI PROTOCOL:

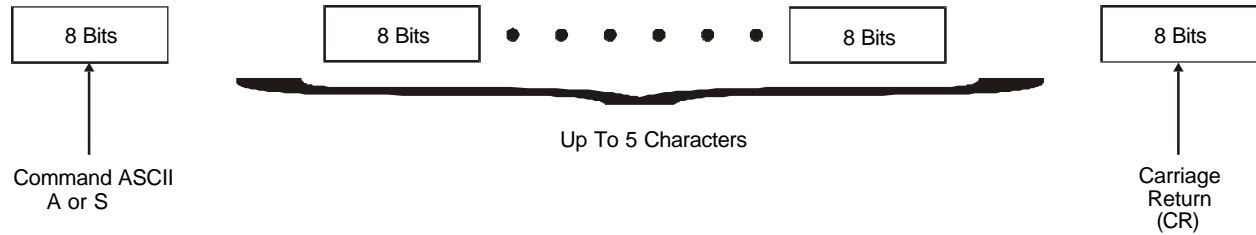

Figure 20

SPI TIMING SPECIFICATIONS:

The following specifications apply to units with software revision 2.21 and later.

Since the polarity of the clock signal is selectable, the setup and hold times are measured relative to the clock edge that latches the data into the unit.

	<u>Minimum</u>	<u>Maximum</u>
Data setup time	100nS.	
Data hold time	100nS.	
Serial clock high time	220nS.	
Serial clock low time	220nS.	

The above parameters will allow a data to be clocked into the device at a rate of at least 2.27 megabits per second. These timing characteristics are specified but not tested at their limits.

MECHANICAL DIMENSIONS

The mechanical dimensions of the DD-100 are shown in Figure 21.

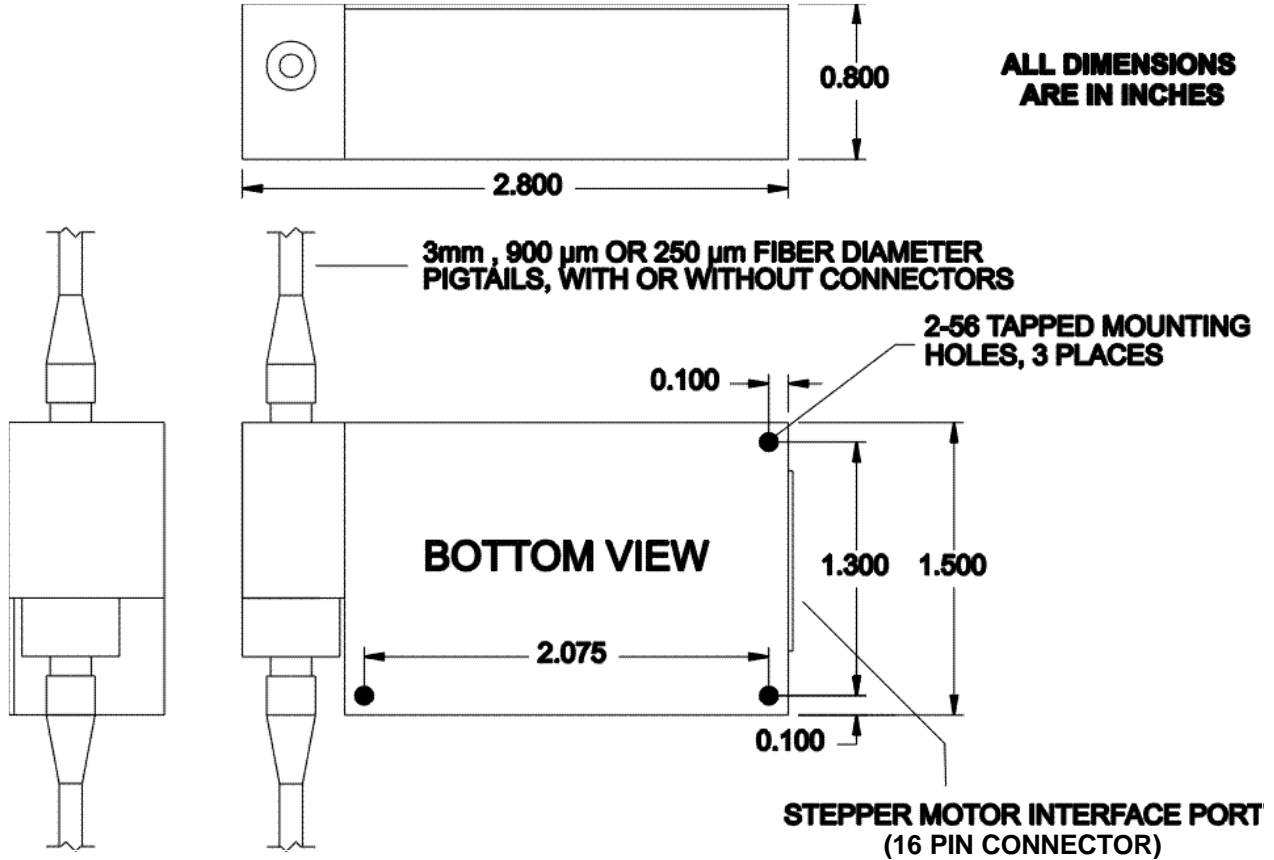

DD STYLE ATTENUATOR

FIGURE 21

ORDERING INFORMATION

The ordering information for the DD-100 is shown in Figure 22 below:

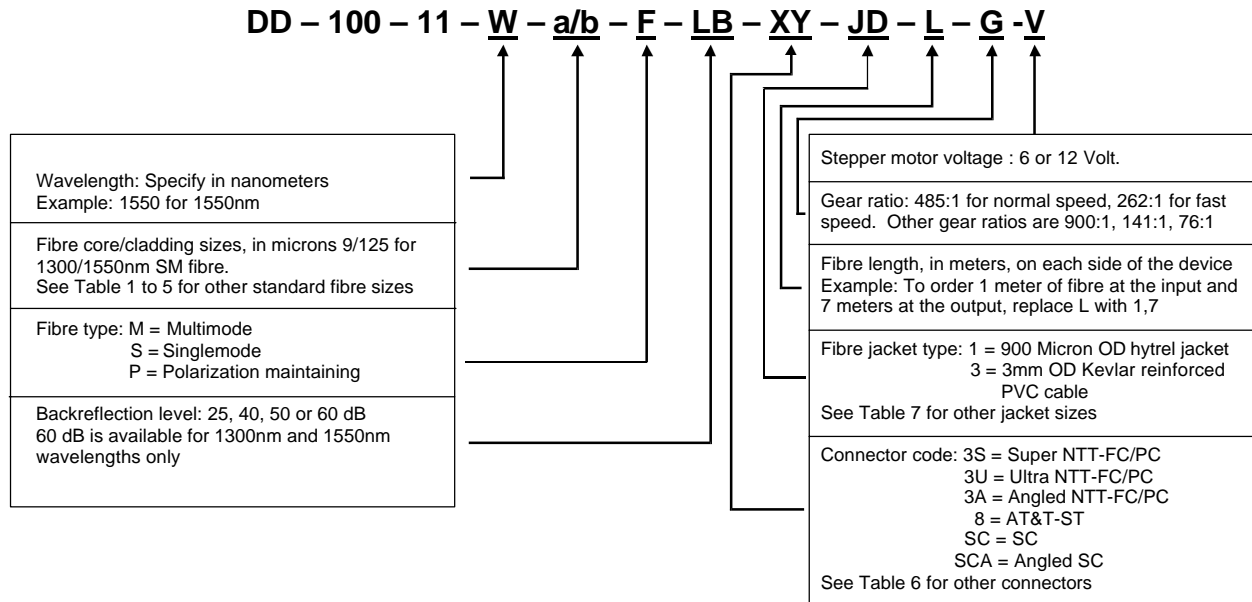

- Add – “DR” to part number to include built – in stepper motor drive electronics.
- “MC/SPI” to part number to include intelligent SPI interface.
 - “MC/IIC” to part number to include intelligent I²C interface.
 - “MC/RS232” to part number to include intelligent RS-232 interface.
 - “LL” to the part number for 0.6dB typical insertion losses.

FIGURE 22

Parts will be supplied with a 16 pin connector. A mating cable assembly is normally supplied with each unit.