



FIBER PIGTAILED ULTRA STABLE LASER MODULE OZ-1000, OZ-2000 & OZ-3000 SERIES

Features:

- Output power up to 300mW
- Wavelengths from 375nm to 2050nm available
- Guaranteed lifetime: 18 months or 5000 hours. Extended warranty is also available
- Excellent power & wavelength stability
- Low RMS noise
- Electrically or optically variable output power
- Easily configured analog interface
- USB interface optional; other interfaces are also available
- Level 4 ESD protection
- Single mode, multimode, or polarization maintaining fiber version
- Available with fiber pigtail or connector receptacle
- Optional collimator or focuser on the pigtail output
- Compact size and low cost

Applications:

- Confocal microscopy
- Flow Cytometry
- DNA Sequencing
- Medical Imaging
- Insertion loss measurement and attenuation measurement
- High power or remote fiber delivery systems
- Accurate fiber optic testing
- Optical component manufacturing and testing
- Materials evaluation and testing
- RGB illumination systems

Product Description:

The OZ-1000, OZ-2000 and OZ-3000 laser modules are temperature stabilized, fiber coupled, laser delivery systems. The compact housings contain both the laser and the temperature control, and are powered by a single 5 volt DC supply. The low noise LD driver and TEC driver maintain the wavelength variation to better than 0.2nm, and also reduces the tendency of the laser diode to mode hop, assuming no feedback into the laser cavity. The electrical interface on the OZ-1000 is located on the front face of the unit alongside the optical interface, while on the OZ-2000 and OZ-3000 it is on the rear of the unit.

The three configurations have a standard analog and TTL interface for OEM applications and an optional computer interface through USB upon request.

The units are equipped with an adjustable output power feature. The output power can be adjusted by simply changing the DC voltage on the Power Control Input. The voltage range is 0 - 5 Volts, with 0 Volts corresponding to maximum power, and 5 Volts minimum power.

The standard parts can be analog modulated at up to 100 kHz. Special versions are available from OZ Optics to cover even higher modulation frequencies, up to 10 MHz for the TTL option. Contact OZ Optics with your requirements.

A manual blocking-style attenuator can be added as an option to adjust the power. This reduces the tendency of the laser diode to change wavelength when varying power by allowing the user to keep the laser diode current constant.

An interlock feature is also standard. This enables the user to shut the unit down if a safety issue or other error condition arises. This feature can also be used as a TTL on/off control. In addition, a mechanical shutter option is available to provide the operator with extra flexibility for controlling laser output power.

The standard OZ-1000, OZ-2000 and OZ-3000 units operate the laser at a fixed temperature.

Both the pigtail and receptacle style sources offer the choice of polarization maintaining, singlemode, or multimode fiber outputs and a wide range of connector or receptacle types. Also available on the fiber output is the choice of either a fiber collimator or fiber focuser.

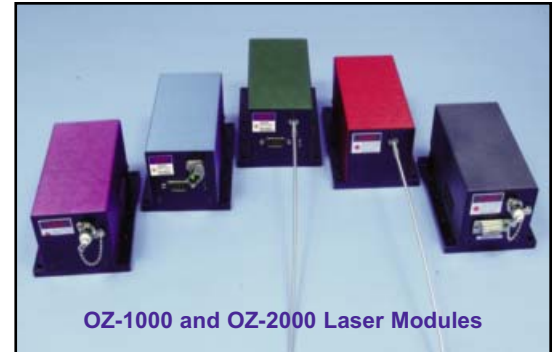

OZ-1000 and OZ-2000 Laser Modules



OZ-3000 Laser Modules



RGB Lasers & RGB Combiner

Standard Product Specifications:

Optical Performance

AVAILABLE WAVELENGTHS ¹ (nm)																				
Wavelength (nm)	375	405	440	473	488	520	532	635	660	685	780	830	850	980	1060	1310	1490 ²	1550	1625	2000
Standard Fiber Coupled Output Power (mW)	0.5 1.0 2.0 3.0	1 10 20 30	5-20	5-30	8-20	5-20	5-20	1 5 10 20 40	10 20 40	10	5 10 35	1 5 10 20 40 60	1 5 10	50 100 300	5 15 50 100 150	1 10 20	1-2	1 10 20	2 5 10	1 2 4
Long-term Power Stability (8 hr) ³	<2%						Typically <2%						Typically <2%				<2%			
Short-term Power Stability (1 min) ³	Typically <0.5% Better stability available as an option						Typically <0.1%						Typically <0.1%				<0.1%			
Polarization Extinction ratio ⁴	>18 dB						>20 dB						>23 dB				>20			
Wavelength Stability ⁵	Typically ± 0.2 nm																			
RMS Noise (20 Hz- 2 MHz)	< 0.2% other than 532 nm																			
Peak to Peak Noise (20 Hz- 2 MHz)	< 0.75% other than 532 nm																			
Fiber Type	Singlemode, Multimode or Polarization maintaining fiber																			

- These are standard center wavelengths. Typical tolerances vary from ± 5nm to ±20nm depending on laser diode manufacturer. Contact OZ Optics if a specific wavelength is required.
- Other available CWDM wavelengths are: 1430, 1450nm, 1470nm, 1510nm, and 1530nm
- Depends on the source wavelength, power level and other options. Refers to typical values achieved at full power over a period of 8 hours for the long-term case and 1 minute for the short-term case after 15 minute warm up time. Tested with low return loss connector at low power laser module with no bias on power control line.
- With polarization maintaining fiber only
- Based on thermal stability achieved with TEC controller and optimum connector termination. Assumes absence of mode-hopping

Electrical Specifications

Power supply	5VDC ±5%
Operating Current	Typically <1.2 A for standard product, 4 A for high power
Power Consumption	<6 W typical
Warm up time	<1 min
Analog/TTL Control Interface	Via 8 pin Din connector.
Computer interface	USB
Power control	0 to 5 V (100% - 1%)
Analog Modulation	Up to 100 kHz
Pulse Modulation	Up to 10 MHz

Analog/TTL interface 8 pin Din connector pin out¹

1	Input	5VDC
2	Input	GND
3	Input	Laser ON/OFF control
4	Input	Power control (analog modulation)
5	Output	Read laser current
6	Output	Read laser monitor current
7	Output	Fault status (Temp fault, over current)
8	Output	Temperature locked

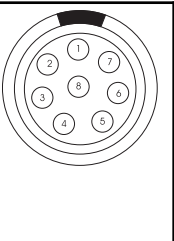

- OZ-3000 PIN configuration alignment may differ depending on requested features. Check product operating instructions to confirm PIN alignment.

Mechanical and Environmental Specifications

Dimensions	114 x 80 x 61 mm (4.50 x 3.15 x 2.40 inch) (OZ 1000 & OZ 2000)
	101.6 x 50 x 38 mm (4 x 2 x 1.5 inch) (OZ 3000)
Operating Temperature	10 to 45 °C
Operating Humidity	0-95% Non-condensing
Storage Temperature	0-50°C



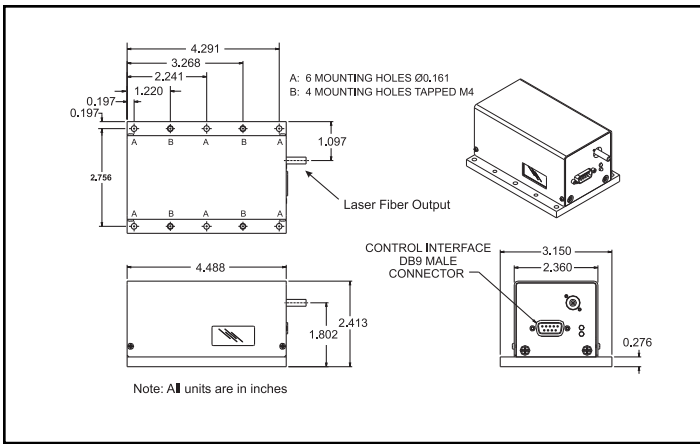

Figure 1: Pigtail style OZ-1000

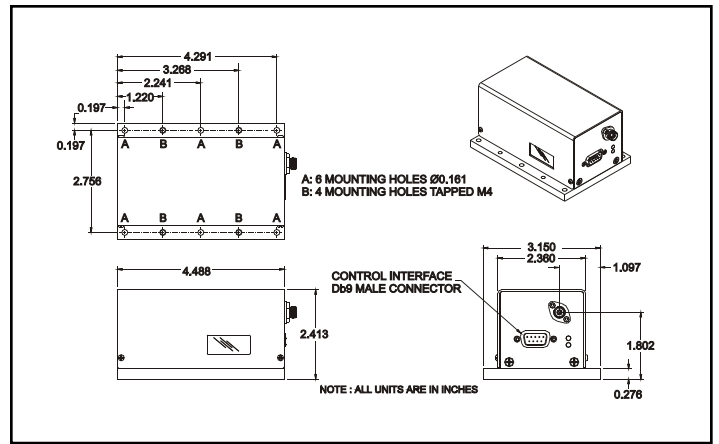

Figure 2: Receptacle style OZ-1000

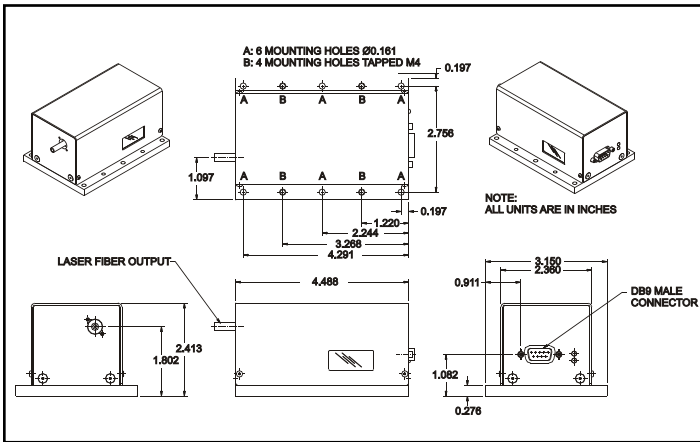

Figure 3: Pigtail style OZ-2000

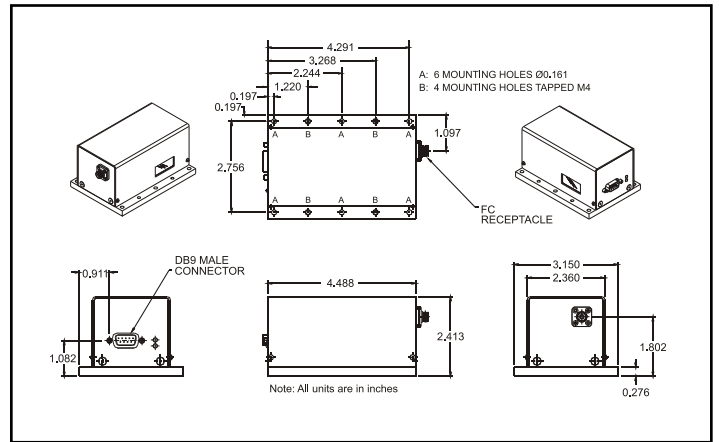

Figure 4: Receptacle style OZ-2000

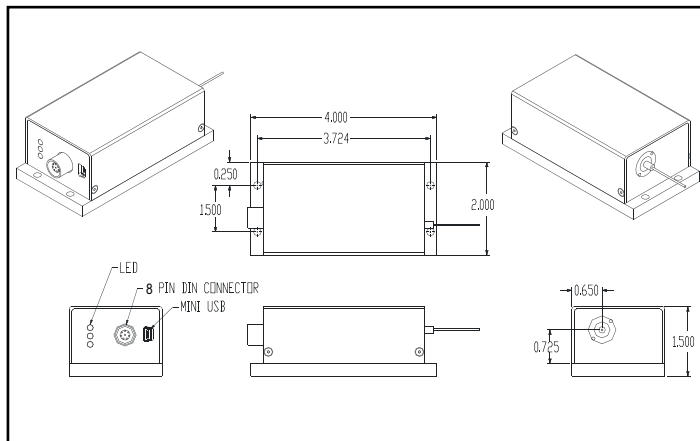

Figure 5: Pigtail style OZ-3000

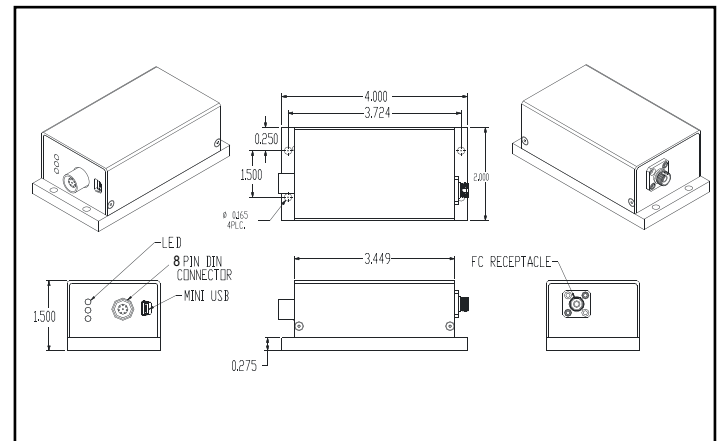

Figure 6: Receptacle style OZ-3000

Warranty And Lifetime

18 months or 5000 hours, whichever comes first when operated under the environmental conditions as stated above. Not applicable for wavelengths less than 600nm, for which the manufacturer's warranty for appropriate laser diodes will apply. The warranty does not apply for damage to exposed fiber or connectors. Please consult OZ Optics for extended warranty for up to 5 years.

Laser Eye Safety

Warning: Up to class 3b product. Read and follow the appropriate laser safety warnings. Avoid direct exposure to the eyes and implement a level of laser safety that is appropriate for this class of laser as serious injury can result from improper use.

Detailed Product Specifications:

375 nm Sources:

Optical Performance

Output Power (mW)	Up to 7 mw
Fiber Type	2/125 μ m SM, 2/125 μ m PM or multimode
Power Stability ¹ - Long term Short term	Typically <2% Typically <0.5%, 0.1% available as an option
Polarization Extinction Ratio ² (dB)	\geq 18 dB
Wavelength Stability ³ (nm)	Typically \pm 0.2nm

- 1 Depends on the power level and other options. Refers to typical values achieved over a period of 24 hours for the long-term case and 1 minute for the short-term case after 15 minutes warm up time and at 100% operating output powers
- 2 With polarization maintaining fiber only
- 3 Based on thermal stability achieved with TEC controller and optimum connector termination with low return loss. Assumes absence of mode-hopping

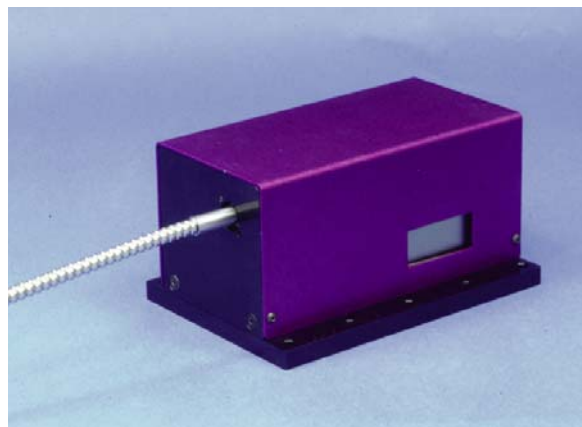

Standard Parts

Bar Code	Part Number	Description
27358	OZ-2000-375-2/125-S-40-3S-3A-1-3	Pigtail style, self-contained thermally stabilized OEM 375nm, 3mW fiber coupled source module. The output fiber is 2/125 micron singlemode, 1m long, 3 mm OD armour cabled fiber terminated with an Super FC/PC connector. Electrical connections are located in the rear panel.

405 nm Sources:

Optical Performance

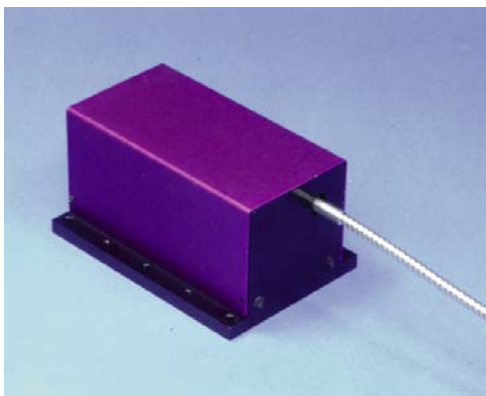

Output Power (mW)	1, 10, 20, 30
Fiber Type	3/125 μ m SM, 3.5/125 μ m PM, or multimode
Power Stability ¹ - Long term Short term	Typically <2% Typically <0.5%, 0.1% available as an option
Polarization Extinction Ratio ² (dB)	\geq 18dB
Wavelength Stability ³ (nm)	Typically \pm 0.2nm

- 1 Depends on the power level and other options. Refers to typical values achieved over a period of 24 hours for the long-term case and 1 minute for the short-term case after 15 minutes warm up time and at 100% operating output powers
- 2 With polarization maintaining fiber only
- 3 Based on thermal stability achieved with TEC controller and optimum connector termination. Assumes absence of mode-hopping

Standard Parts

Bar Code	Part Number	Description
17534	OZ-1000-405-3.5/125-P-40-3A-3-1-1	Pigtail style, self-contained OEM 405nm, 1mW fiber coupled source module. The output fiber is 3.5/125 micron PANDA style polarization maintaining fiber, 1 meter long, with 3mm Kevlar jacketed cable and terminated with an angled FC/APC connector. The output polarization is aligned parallel to the connector key. Electrical connections are on the front panel.
19431	OZ-1000-405-3/125-S-40-3S-3A-1-1	Pigtail style, self-contained thermally stabilized OEM 405nm, 1mW fiber coupled source module. The output fiber is 3/125 micron SM, 1m long, with 3 mm armoured fiber terminated with a super FC/PC connector. Electrical connections are on the front panel.
19424	OZ-2000-405-3/125-S-40-3S-3A-1-1	Pigtail style, self-contained thermally stabilized OEM 405nm, 1mW fiber coupled source module. The output fiber is 3/125 micron SM, 1m long, with 3 mm armoured fiber terminated with a super FC/PC connector. Electrical connections are located in rear panel.
19426	OZ-1000-405-3/125-S-40-3S-3A-1-10	Pigtail style, self-contained thermally stabilized OEM 405nm, 8 - 10mW fiber coupled source module. The output fiber is 3/125 micron SM, 1m long, with 3 mm armoured fiber terminated with a super FC/PC connector. Electrical connections are on the front panel.
20071	OZ-2000-405-3/125-S-40-3S-3A-1-10	Pigtail style, self-contained thermally stabilized OEM 405nm, 8 - 10mW fiber coupled source module. The output fiber is 3/125 micron SM, 1m long, with 3 mm armoured fiber terminated with a super FC/PC connector. Electrical connections are located in rear panel.
27393	OZ-2000-405-3.5/125-P-40-3S-3A-1-30	Pigtail style, self-contained thermally stabilized OEM 405nm, 30mW fiber coupled source module. The output fiber is 3.5/125 PANDA style polarization maintaining fiber, 1 meter long, with 3 mm armoured cable and terminated with a Super FC/PC connector. Electrical connections are located in rear panel.

**440-520 nm Sources:
Optical Performance**

Output Power (mW)	Up to 20mW @ 440 nm, 488 nm, and 520 nm and up to 30mW @ 473 nm
Fiber Type	3.5/125 µm SM, 3.5/125 µm PM, or multimode
Power Stability ¹ - Long term Short term	Typically <2% Typically <0.5%, 0.1% available as an option
Polarization Extinction Ratio ² (dB)	≥18dB
Wavelength Stability ³ (nm)	Typically ± 0.2nm

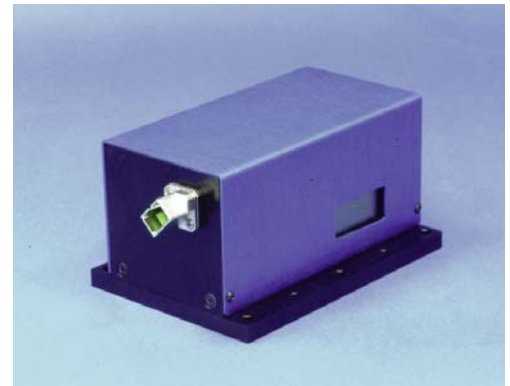

- 1 Depends on the power level and other options. Refers to typical values achieved over a period of 24 hours for the long-term case and 1 minute for the short-term case after 15 minutes warm up time and at 100% operating output powers
- 2 With polarization maintaining fiber only
- 3 Based on thermal stability achieved with TEC controller and optimum connector termination. Assumes absence of mode-hopping

Standard Parts

Bar Code	Part Number	Description
27357	OZ-2000-440-3.5/125-S-40-3S-3A-1-10	Pigtail style, self-contained thermally stabilized OEM 440nm, 10mW fiber coupled source module. The output fiber is 3.5/125 micron singlemode fiber, 1m long, with 3 mm armoured fiber terminated with a super FC/PC connector. Electrical connections are located in rear panel.
27359	OZ-2000-473-3.5/125-S-40-3S-3A-1-5	Pigtail style, self-contained thermally stabilized OEM 473nm, 5mW fiber coupled source module. The output fiber is 3.5/125 micron singlemode, 1m long, 3 mm OD armour cabled fiber, terminated with a Super FC/PC connector. Electrical connections are located in rear panel.

**532¹ nm Sources:
Optical Performance**



Output Power (mW)	Up to 20
Fiber Type	3.5/125 µm SM, 3.5/125 µm PM, or multimode
Power Stability ² - Long term Short term	Typically <5% Typically <0.5%
Polarization Extinction Ratio ³ (dB)	≥18dB
Wavelength Stability ⁴ (nm)	Typically ± 0.2nm

- 1 Unit is built using a diode pumped solid state laser
- 2 Depends on the power level and other options. Refers to typical values achieved over a period of 24 hours for the long-term case and 1 minute for the short-term case after 15 minutes warm up time and at 100% operating output powers
- 3 With polarization maintaining fiber only
- 4 Based on thermal stability achieved with TEC controller and optimum connector termination. Assumes absence of mode-hopping

Standard Parts

Bar Code	Part Number	Description
27360	OZ-2000-532-3.5/125-S-40-3S-3A-1-20	Pigtail style, self-contained thermally stabilized OEM 532nm, 20mW fiber coupled source module. The output fiber is 3.5/125 micron singlemode, 1m long, 3 mm OD armour cabled fiber terminated with an Super FC/PC connector. Electrical connections are located in the rear panel.

**635-730 nm Sources:
Optical Performance**

Output Power (mW)	1, 5, 10, 20 at various wavelengths - please consult OZ Optics with your requirements
Fiber Type	4/125 μ m SM, 4/125 μ m PM, or multimode
Power Stability ¹ - Long term Short term	Typically <2% Typically <0.1%
Polarization Extinction Ratio ² (dB)	>20
Wavelength Stability ³ (nm)	Typically \pm 0.2nm

- ¹ Depends on the power level and other options. Refers to typical values achieved over a period of 24 hours for the long-term case and 1 minute for the short-term case after 15 minutes warm up time and at 100% operating output powers
- ² With polarization maintaining fiber only
- ³ Based on thermal stability achieved with TEC controller and optimum connector termination. Assumes absence of mode-hopping



Standard Parts

Bar Code	Part Number	Description
19430	OZ-1000-635-4/125-S-40-3S-3A-1-1	Pigtail style, self-contained thermally stabilized OEM 635nm, 1mW fiber coupled source module. The output fiber is 4/125 micron SM, 1m long, with 3 mm armoured fiber terminated with a super FC/PC connector. Electrical connections are located on the front panel.
19429	OZ-2000-635-4/125-S-40-3S-3A-1-1	Pigtail style, self-contained thermally stabilized OEM 635nm, 1mW fiber coupled source module. The output fiber is 4/125 micron SM, 1m long, with 3 mm armoured fiber terminated with a super FC/PC connector. Electrical connections are located in rear panel
19428	OZ-2000-635-4/125-S-40-3S-3A-1-10	Pigtail style, self-contained thermally stabilized OEM 635nm, 10mW fiber coupled source module. The output fiber is 4/125 micron SM, 1m long, with 3 mm armoured fiber terminated with a super FC/PC connector. Electrical connections are located in rear panel
19427	OZ-1000-635-4/125-S-40-3S-3A-1-10	Pigtail style, self-contained thermally stabilized OEM 635nm, 10mW fiber coupled source module. The output fiber is 4/125 micron SM, 1m long, with 3 mm armoured fiber terminated with a super FC/PC connector. Electrical connections are located on the front panel.
18359	OZ-1000-3S-50/125-635-M-25	Receptacle style, self-contained, thermally stabilized, OEM laser diode to fiber coupler module 635nm with 25mW output and a 50/125 MM fiber terminated with a super FC/PC receptacle. Electrical connections are located on the front panel.
16780	OZ-1000-660-4/125-P-50-3S-5A-0.5-20	Pigtail style, self-contained OEM laser diode to fiber coupler module 660nm, 18-20mW output, 0.5m long, 5 mm armoured 4/125 PM fiber terminated with an FC super PC connector. Slow axis of PM fiber aligned with connector keyway. Electrical connections are located on the front panel.
26381	OZ-1000-680-4/125-S-40-3S-3A-1-10	Self-contained OEM Fabry Perot laser diode to fiber coupler module 680nm, 10-12mW output, 1m long, 3 mm armoured 4/125 SM fiber terminated with an FC super PC connector. Electrical connections are located on the front panel.

**750-850 nm Sources:
Optical Performance**

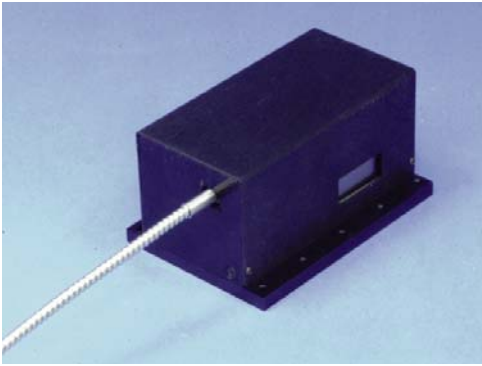

Output Power (mW)	1, 5, 10, 20, 35, 40, 60 at various wavelengths - please consult OZ Optics with your requirements
Fiber Type	5/125 μ m SM, 5/125 μ m PM, or multimode
Power Stability ¹ - Long term Short term	Typically <2% Typically <0.1%
Polarization Extinction Ratio ² (dB)	≥ 20
Wavelength Stability ³ (nm)	Typically ± 0.2 nm

- 1 Depends on the power level and other options. Refers to typical values achieved over a period of 24 hours for the long-term case and 1 minute for the short-term case after 15 minutes warm up time and at 100% operating output powers
- 2 With polarization maintaining fiber only
- 3 Based on thermal stability achieved with TEC controller and optimum connector termination. Assumes absence of mode-hopping

Standard Parts

Bar Code	Part Number	Description
18834	OZ-1000-780-5/125-S-40-3U-3-1-5	Pigtail style, self-contained thermally stabilized OEM laser diode to fiber coupler module 780nm, 5mW output, 1m long, 3mm OD PVC cabled 5/125 SM fiber terminated with an ultra FC/UPC connector. Electrical connections are located on the front panel.
15139	OZ-1000-830-5/125-P-60-3S-5A-0.5-60	Pigtail style, self-contained OEM laser diode to fiber coupler module 830nm, 60mW output, 0.5m long, 5mm black armored 5/125 PM fiber terminated with a super FC/PC connector. The slow axis of the PM fiber is aligned to the connector keyway. Includes a PMPC FC/PC sleeve-thru adaptor with a 2.06mm keyway. Electrical connections are located on the front panel.
23075	OZ-2000-830-5/125-P-40-3A-1-1-10	Pigtail style, self-contained thermally stabilized OEM 830nm, 10mW fiber coupled source module with 1m long, 1 mm OD jacketed, 5/125 micron PM fiber, terminated with an angled FC/APC connector aligned and locked along slow axis. Electrical connections are located in rear panel.
21613	OZ-2000-850-5/125-S-40-3S-3-1-50	Pigtail style, self-contained thermally stabilized OEM 850nm, 50mW fiber coupled source module with 1m long, 3 mm OD PVC cabled, 5/125 micron SM fiber, terminated with a super FC/PC connector. Electrical connections are located in rear panel.
22590	OZ-2000-3A-5/125-830-P-10	Receptacle style, self-contained thermally stabilized OEM 830nm FP, 10mW fiber coupled source module. The fiber inside is a 5/125 μ m PM fiber terminated with an angled FC/APC connector with a key aligned and locked along the fiber slow axis. Electrical connections are located in rear panel.

**960-1100 nm Sources:
Optical Performance**

Output Power (mW)	Up to 300 @ 980 nm and up to 150 @ 1060 nm
Fiber Type	6/125 μ m SM, 5or 6/125 μ m PM, or multimode
Power Stability ¹ - Long term Short term	Typically <2% Typically <0.1%
Polarization Extinction Ratio ² (dB)	≥ 20
Wavelength Stability ³ (nm)	Typically ± 0.2 nm

- 1 Depends on the power level and other options. Refers to typical values achieved over a period of 24 hours for the long-term case and 1 minute for the short-term case after 15 minutes warm up time and at 100% operating output powers
- 2 With polarization maintaining fiber only
- 3 Based on thermal stability achieved with TEC controller and optimum connector termination. Assumes absence of mode-hopping

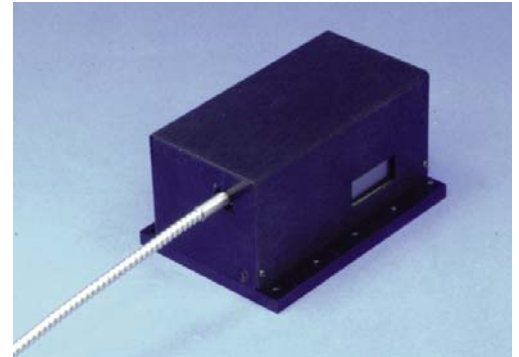

Standard Parts

Bar Code	Part Number	Description
21614	OZ-2000-980-6/125-S-40-3S-3-1-50	Pigtail style, self-contained thermally stabilized OEM 980nm, 50mW fiber coupled source module with 1m long, 3 mm OD PVC cabled, 6/125 micron SM fiber, terminated with a super FC/PC connector. Electrical connections are located in rear panel.
21885	OZ-2000-1064-6/125-P-40-3A-3-1-10	Pigtail style, self-contained thermally stabilized OEM 1064 ± 5 nm, 10mW fiber coupled source module. The output fiber is 6/125 micron PM, 1m long, 3 mm OD PVC cabled fiber terminated with an angled FC/APC connector with a key that aligned and locked along fiber slow axis. Electrical connections are located in rear panel.
22532	OZ-2000-3A-6/125-980-P-50	Receptacle style, self-contained thermally stabilized OEM 980nm, 6/125 micron PM fiber, 50mW fiber coupled source module terminated with an angle FC/APC connector with slow axis aligned and locked along the slow axis. Electrical connections are located in rear panel.

**1310-1490 nm Sources:
Optical Performance**

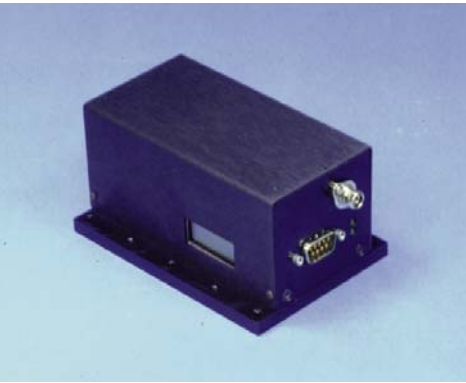

Output Power (mW)	Up to 20 @ 1310 nm and up to 2 @ 1490 nm
Fiber Type	9/125 μm SM, 7/125 μm PM, or multimode
Power Stability ¹ - Long term	Typically <1%
Short term	Typically <0.05%
Polarization Extinction Ratio ² (dB)	≥23
Wavelength Stability ³ (nm)	Typically ± 0.2nm

- ¹ Depends on source wavelength, power level and other options. Refers to typical values achieved over a period of 24 hours for the long-term case and 1 minute for the short-term case after 15 minutes warm up time and at 100% operating output powers
- ² With polarization maintaining fiber only
- ³ Based on thermal stability achieved with TEC controller and optimum connector termination. Assumes absence of mode-hopping

Standard Parts

Bar Code	Part Number	Description
23090	OZ-2000-3S-50/125-1310-M-2	Receptacle style, self-contained thermally stabilized OEM 1310nm, 2mW fiber coupled source module. The fiber inside is a 50/125μm MM fiber terminated with a super FC/PC receptacle. Electrical connections are located in rear panel.
26404	OZ-2000-1310-9/125-S-40-3S-3-1-20	Pigtail style, self-contained thermally stabilized OEM 1310nm, 20mW fiber coupled source module with 1m long, 3 mm OD PVC cabled, 9/125 micron SM fiber, terminated with a super FC/PC connector. Electrical connections are located in rear panel.

**1550-2050 nm Sources:
Optical Performance**

Output Power (mW)	Up to 15 @ 1550 nm and up to 10 @ 2000 nm
Fiber Type	9/125 μm SM, 8/125 μm PM, or multimode
Power Stability ¹ - Long term	Typically <1%
Short term	Typically <0.05% ; <0.1% for 2000 nm
Polarization Extinction Ratio ² (dB)	≥23 ; >20 dB for 2000 nm
Wavelength Stability ³ (nm)	Typically ± 0.2nm

- ¹ Depends on source wavelength, power level and other options. Refers to typical values achieved over a period of 24 hours for the long-term case and 1 minute for the short-term case after 15 minutes warm up time and at 100% operating output powers
- ² With polarization maintaining fiber only
- ³ Based on thermal stability achieved with TEC controller and optimum connector termination. Assumes absence of mode-hopping

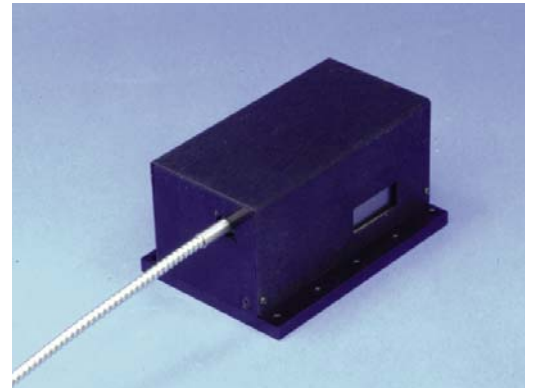

Standard Parts

Bar Code	Part Number	Description
22876	OZ-2000-1550-8/125-P-40-3A-3-1-1.5	Pigtail style, self-contained thermally stabilized OEM 1550 ±5nm, 1.5mW fiber coupled source module. The output fiber is 8/125 micron PM, 1m long, 3 mm OD cabled fiber terminated with an angled FC/APC connector with a key that aligned and locked along fiber slow axis. Electrical connections are located in rear panel.
26877	OZ-1000-3S-8/125-1550-P-10-DFB	Receptacle style, self-contained, TE cooled, OEM DFB laser diode to fiber coupler module 1550+/-5nm with 10mW output, and a 8/125 PM fiber terminated with an FC/PC receptacle with key aligned and locked along the slow axis.
26920	OZ-2000-3S-9/125-1550-S-1-DFB	Receptacle style, self-contained thermally stabilized DFB 1550nm+/-5nm, 1mW fiber coupled source module with 9/125 μm SM terminated with an FC/PC connector. Electrical connections are located in rear panel. Internal Isolator included.
25706	OZ-2000-1550-9/125-S-40-3S-3A-1-10	Pigtail style, self-contained thermally stabilized OEM 1550nm, 10mW fiber coupled source module. The output fiber is 9/125 micron SM, 1m long, with 3 mm armour fiber terminated with a super FC/PC connector. Electrical connections are located in rear panel.

Power supply units:

Bar Code	Part Number	Description
11147	AC-5VDC-NA	Universal 110/220 VAC to 5-volt DC power supply, 30 Watts, 4 Amps, w/ IEC power cord to North American Plug.
12388	AC-5VDC-EU	Universal 110/220 VAC to 5-volt DC power supply, 30 Watts, 4 Amps, w/ IEC power cord to European Plug.
16885	AC-5VDC-UK	Universal 110/220 VAC to 5-volt DC power supply, 30 Watts, 4 Amps, w/ IEC power cord to United Kingdom Plug.

Ordering Examples For Standard Parts:

A customer needs a temperature stabilized, 635nm source capable of delivering over 10mW from the end of a singlemode fiber terminated with an FC/PC connector. They also require a 5-volt DC supply with a standard North American wall plug.

Bar Code	Part Number	Description
19427	OZ-1000-635-4/125-S-40-3S-3A-1-10	Pigtail style, self-contained thermally stabilized OEM 635nm, 10mW fiber coupled source module. The output fiber is 4/125 micron SM, 1m long, with 3 mm armored fiber terminated with a super FC/PC connector. Electrical connections are located on the front panel.
11147	AC-5VDC-NA	Universal 110/220 VAC to 5-volt DC power supply, 30 Watts, 4 Amps, w/ IEC power cord to North American Plug.

Ordering Information For Custom Parts:

OZ Optics welcomes the opportunity to provide custom designed products to meet your application needs. As with most manufacturers, customized products do take additional effort so please expect some differences in the pricing compared to our standard parts list. In particular, we will need additional time to prepare a comprehensive quotation, and lead times will be longer than normal. In certain cases non-recurring engineering (NRE) charges, lot charges, and/or a minimum order will be necessary. These points will be carefully explained in your quotation, so your decision will be as well-informed as possible.

Questionnaire

1. What wavelength do you need?
2. How much output power do you need?
3. Do you want a built-in fiber, or a receptacle to attach your own fiber?
4. What size and type of fiber do you require?
5. How long a fiber do you need?
6. What kind of fiber connectors are you using?
7. Do you need a collimated output beam?
8. If a collimated beam is required, what is the desired beam diameter?
9. If a focused spot is required, what is the desired spot size and working distance?
10. Do you want a built-in isolator?

Description:

Pigtail Style Source

Part Number

OZ-N000-W-a/b-F-LB-X-JD-L-P

N = 1000 for electrical & optical connections in same front panel

2000 for electrical connection on rear panel & optical connection on front panel

3000 compact version

W = Wavelength ¹: 375, 405, 440, 473, 488, 532, 635, 660, 685, 780, 830, 850, 980, 1060, 1310, 1490, 1550, 1625.

a/b = Fiber size: core/cladding diameters (in μm): (see tables 1 to 5 in the Standard Tables data sheet)

F = Fiber type: M = Multimode Fiber
S = Singlemode Fiber
P = Polarization Maintaining Fiber

LB = Backreflection level ²:

35 = 35dB return loss (MM only)

40 = 40dB return loss (SM & PM)

60 = 60dB return loss

(SM & PM - 1300/1550nm only)

P = Output power available from the fiber end, in mW ³

L = Fiber length (in meters)

JD = Jacket Diameter:

1 = 900 μm jacketed fiber

3 = 3mm OD Kevlar jacketed fiber

3A = 3mm OD black armored cable

3AS = 3mm OD Stainless Steel armored cable

5A = 5mm OD black armored cable

5AS = 5mm OD Stainless Steel armored cable

X = Connector type: 3 = FC/PC

3S = Super FC/PC

3A = Angled FC/APC

5 = SMA905

8 = AT&T-ST

SC = SC or ultra SC

SCA = Angled SC

EA = Angled E2000

LC = LC connector

For other connector types contact OZ Optics.

Description:
Receptacle Style Source

Part Number
OZ-N000-X-a/b-W-F-P

N = 1000 for electrical & optical connections in same front panel
2000 for electrical connection on rear panel & optical connection on front panel
3000 compact version

X = Connector Receptacle:
2.5U = 2.5mm universal receptacle (for FC, ST, or SC).
3S = Super FC/PC
3A = Angled FC/APC
5 = SMA905
8 = AT&T-ST
SC = SC
SCA = Angled SC

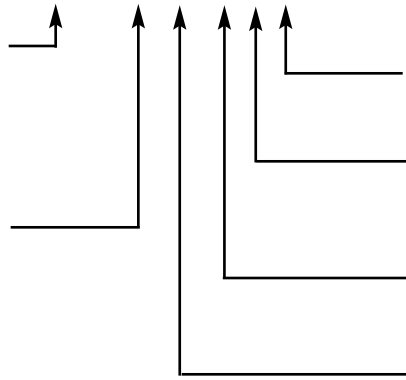

P = Output power ³:
Output power available from the receptacle

F = Fiber type: M = Multimode Fiber
S = Singlemode Fiber
P = Polarization Maintaining Fiber

W = Wavelength ¹: 375, 405, 440, 473, 488, 532, 635, 660, 685, 780, 830, 850, 980, 1060, 1310, 1490, 1550, 1625.

a/b = Fiber size: core/cladding diameters (in μm):
(see Tables 1 to 5 in the Standard Tables data sheet)

1 These are standard center wavelength values. The tolerance may vary depending on both wavelength and the laser diode manufacturers' tolerances. (Typical tolerances vary from $\pm 5\text{nm}$ to as high as $\pm 30\text{nm}$).

2 The backreflection specification refers to the reflected signal strength relative to the output power seen by the laser diode from internal reflections. It does not include external sources of reflection, including those from the connector at the end of the fiber. To minimize external reflections, OZ Optics recommends using angle polished FC/APC or SC/APC connectors. Backreflection values are limited by the wavelength and fiber type selected. Other backreflection levels may be possible. Please contact OZ for further information.

3 Note that due to variations in the optical characteristics of the laser diodes available, not all output powers are available at every wavelength for every fiber type. For wavelengths below 750nm, we recommend pigtail style to eliminate connection loss at the receptacle interface.

- Options:** Add **"-ISOL"** if an optical isolator is required (Please note that this option is only available for the 1300 to 1625nm wavelength range).
Add **"-SH"** For shutter.
Add **"-TTL"** For up to 155MHz modulation.
Add **"-CSP"** For customer supplied laser diode or fiber.
Add **"-USB"** For computer interface.

Ordering Examples for Custom Parts:

A European customer needs a temperature stabilized, 635nm source capable of delivering 15mW from the end of a 1m long, 3mm Stainless Steel cabled singlemode fiber.

These requirements can be met by using a pigtailed source with part number OZ-1000-635-4/125-S-40-3A-3AS-1-20. This provides 5 mW of headroom, to accommodate any degradation of the laser over time.

Frequently Asked Questions (FAQs)

Q: What is the difference between the OZ-1000 and OZ-2000 systems?

A: The OZ-1000 has its electrical interface located on the front panel where the optical connector is located. The OZ-2000 has its electrical interface located on the rear panel opposite of where the optical connector is located. This is to best suit our customers' needs. In all other aspects, the units are identical.

Q: Since the interlock feature is TTL compatible, can I use it as a TTL input for modulation?

A: No, although the interlock is TTL compatible, it should only be used for turning the unit on or off through a computer interface or via a safety switch.

Q: Do the sources have a modulation function?

A: A standard OZ-1000 or OZ-2000 can be modulated at low frequencies by feeding the modulation signal to the power control input. The power control signal varies the output power from 100% to 0% as the voltage changes from 0 volts to 5 volts. Most applications using modulation would require a modulation signal with a DC offset. The standard units use filters to minimize noise in the drive circuitry so as to give the cleanest possible optical signal. However, these filters also limit the bandwidth of the output. For applications that require a higher modulation capability, the bandwidth limitation can be reduced at the factory, to allow modulation of over 100 kHz. Contact OZ Optics if modulation above a few kHz is required.

Q: Many laser diodes require less than 100 mA. Why does the OZ-1000 require >1 amp?

A: Most of the current required by the OZ-1000 is used by the Peltier element that maintains the laser at a constant operating temperature. A constant temperature is required to ensure the best possible stability, both in terms of power stability and wavelength stability. Under certain conditions, the Peltier element may require a significant current. This is especially true when the laser is first turned on, and the Peltier driver circuitry is working hard to achieve the desired operating temperature. Once the desired temperature is reached, the operating current will generally drop significantly.

Q: Can OZ Optics manufacture sources using a customer supplied laser diode and/or fiber?

A: Yes. Please provide OZ Optics with detailed information.

Q: Does OZ Optics offer higher power sources than what is standard on the data sheet?

A: Yes. Please provide OZ Optics with the requested fiber output power and fiber type and we will work with you to find a solution.

Q: Do you offer universal adaptors for your sources?

A: We can, but we do not recommend them. Universal adaptors do not have a retaining mechanism, so the fiber can fall out if you do not hold it in place. In addition, the lack of a retaining mechanism will cause the coupled power from the source to be unstable. Universal receptacles should only be used with visible sources for fault location, where you are not concerned with the power stability.

Q: Why do you recommend the pigtail style for wavelengths below 750nm?

A: For wavelengths less than 750nm, the fiber core size is 4 microns or smaller. For such small sizes, mechanical tolerances may result in over 1dB (20%) losses at the receptacle interface. Using a pigtail style unit avoids this issue.

Q: Does OZ Optics offer a way to combine different wavelengths through a single fiber?

A: Yes, using a wavelength division multiplexer (WDM), OZ Optics can combine up to 3 wavelengths into a single fiber. For example, OZ Optics offers a Red, Green, Blue (RGB) combiner. Please see the data sheet titled "*RGB (Red Green Blue) Combiner and Delivery Systems*".

Q: I currently use units that had the D-Sub connector. How can I use the new units with the DIN connector?

A: OZ Optics has available a cable to adapt the DIN connector to a D-Sub connector.

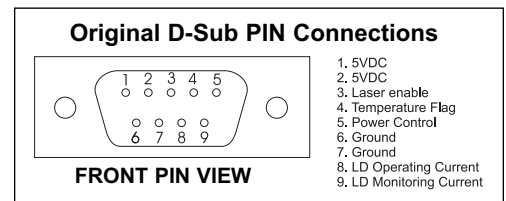

Application Notes

Insertion loss and attenuation measurement

When used with an optical power meter, the OZ-1000 & OZ-2000 can provide an alternative to insertion loss and backreflection test sets, due to their excellent stability. For singlemode applications, such as telecom or CATV environments, the OZ-1000 & OZ-2000 can be coupled with an optical power meter to form a test kit that performs optical loss tests at 1300 or 1550nm.

Maintenance

To ensure the best performance of your source, some simple maintenance is required.

Cleaning the connector: A clean connector ensures that good connections are made between the source and the fiber under test. Failure to clean the connectors can cause permanent damage to both the fiber end and the connector of the source. To avoid these failures, ensure that the unit is OFF, and clean the connector before each use with a fresh lint-free tissue and alcohol.

Using bare fibers with sources

A common application is to connect a fiber without any connector (bare fiber) to a source. **Do not attempt to attach a bare fiber directly to the source with a bare fiber adaptor or similar device.** Instead the best approach is to use an intermediate patchcord, with the appropriate connector on one end, and a bare fiber on the other end. The end with the connector is attached to the source or meter, and the bare fiber end is connected to the bare fiber on the device to be tested. Both fibers are first stripped, cleaned and cleaved then spliced together. This can be done with a fusion splicer, or alternatively, a simple mechanical splice (OZ Bar Code #1933) can be used. Each fiber end is first dabbed into index matching gel (GEL-01, OZ Bar Code# 2861) to act as a lubricant (Note: Index Matching Gel is only suitable for <10mW power levels, and wavelengths longer than 600nm). One end is inserted about half way into the splice, while the other end is pushed in until it butts against the other fiber. Losses are typically less than 1dB, and the parts can be reused.

Computer interface functions

1	Set the temperature (Factory preset)
2	Set the laser power (Factory preset)
3	Set the current limit (Factory preset)
4	Read the operating time
5	Laser ON/OFF
6	Laser power control (0 to 100%)
7	Laser status
8	Read laser current
9	Read laser monitor current
10	Fault status (Temp fault, laser over current)
11	Temperature locked

Operating Lifetimes of OZ Optics Fiber Pigtailed Laser Modules

OZ Optics has spent significant research in developing laser modules with high reliability and long operating lifetimes. The following charts give typical test data for optical sources that we have produced. While actual operating lifetimes depend on the operating wavelength, laser power, and reliability data for the laser diodes by the manufacturers, the data given indicates the reliability of the optics and control electronics developed by OZ Optics.

Example 1: 670nm sources.

Chart #1 shows the output power over time for six fiber sources, pigtailed with polarization maintaining fiber. All six sources emit 1mW of laser power at 670nm. A forward monitoring optical tap controlled optical power. The devices were left to operate at room temperature continuously. As indicated in the chart, all six devices have operated for over a year, with less than a 1% drop in overall power, and are expected to operate at least 3 years with less than 5% change in the overall power.

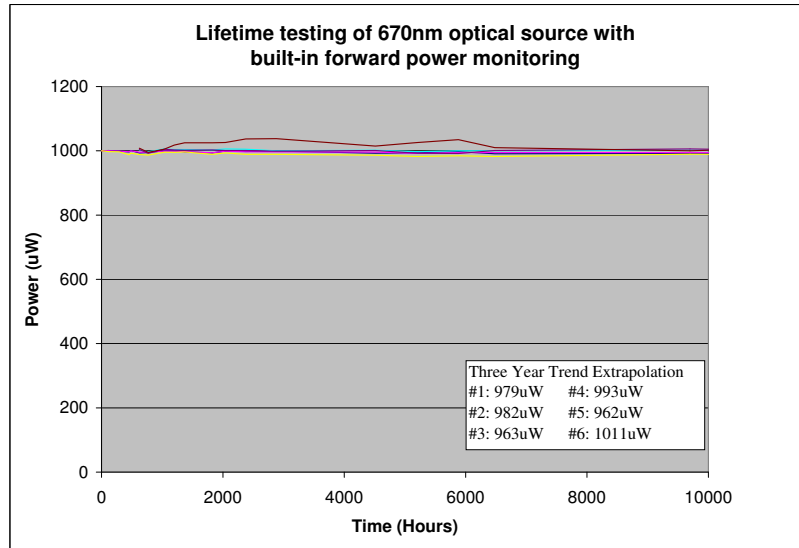

Chart #1: 670nm source lifetime testing

Example 2: 405nm sources

Chart #2 shows the output power over time for three fiber sources, again pigtailed with polarization maintaining fiber. All three sources emit over 30mW of laser power at 405nm. Power was controlled using the internal monitor photodiode inside the laser diode housing. The devices were left to operate at room temperature continuously. As indicated in the chart, all the units were able to run for over 1500 hours with less than a 3% drop in overall power.

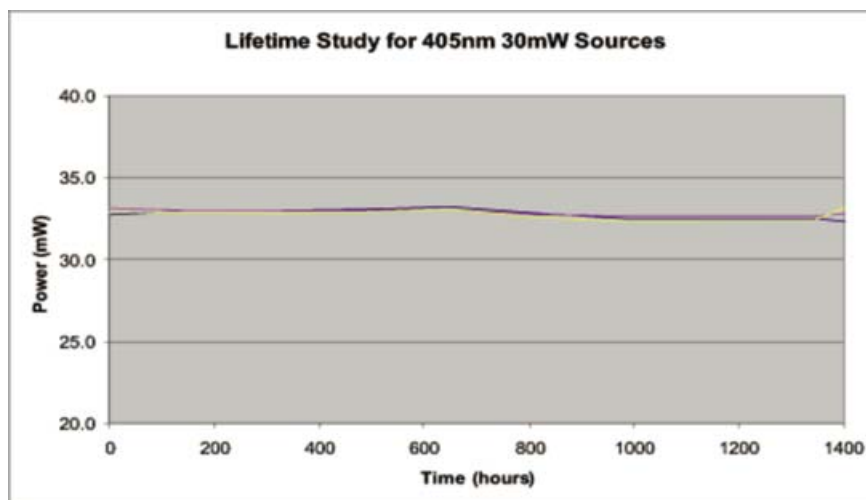

Chart #2: 405nm source lifetime testing