

# EXS210098-01

## SLED Butterfly 635nm

**Revision:** 1.0  
**Date:** 23-10-2018  
**Confidentiality:** **None**

**Prepared by:** Raffaele Rezzonico  
(Product Support Technician)

**Checked by:** Marco Rossetti  
(Product Line Manager)

**Approved by:** Philipp Vorreau  
(Quality Manager)

## CONTENTS

|   |          |
|---|----------|
| <b>1. SCOPE</b> .....   | <b>3</b> |
| 1.1 PURPOSE.....  | 3        |
| 1.2 RESPONSIBILITY .....  | 3        |
| <b>2. REFERENCE DOCUMENT</b> .....                                    | <b>3</b> |
| <b>3. ELECTRO-OPTICAL PERFORMANCE (T<sub>SLED</sub> = 25°C)</b> ..... | <b>3</b> |
| <b>4. ABSOLUTE MAXIMUM RATINGS</b> .....                              | <b>4</b> |
| 4.1 ELECTRICAL TURN-ON CHARACTERISTICS .....                          | 4        |
| <b>5. SCREENING</b> .....   | <b>4</b> |
| <b>6. PACKAGE DIMENSIONS [MM]</b> .....                               | <b>5</b> |
| <b>7. FIBRE AND CONNECTOR</b> .....                                   | <b>5</b> |
| <b>8. IMPORTANT NOTES</b> .....                                       | <b>6</b> |
| <b>9. ORDERING INFORMATION</b> .....                                  | <b>6</b> |
| 9.1 TECHNICAL DESCRIPTION.....  | 6        |
| <b>10. REVISION HISTORY</b> .....                                     | <b>7</b> |

## 1. SCOPE

### 1.1 PURPOSE

The purpose of this document is to specify the electro-optical performance and dimensions of superluminescent light emitting diode (SLED).

### 1.2 RESPONSIBILITY

EXALOS is responsible for establishing, implementing and maintaining this procedure. The Quality representative shall ensure that a timely Engineering Change Notice (ECN) is issued in accordance with EXALOS procedure for any changes.

## 2. REFERENCE DOCUMENT

- EXS-WI-0001 Visual Inspection Criteria SLED Chip on Submount Procedure
- MIL STD 883 C method.
- Bellcore GR-468-CORE.

## 3. ELECTRO-OPTICAL PERFORMANCE ( $T_{SLED} = 25^{\circ}C$ )

| Parameter                  | Symbol      | Cond.         | Min | Typ | Max | Unit |
|----------------------------|-------------|---------------|-----|-----|-----|------|
| Operating Current          | $I_{op}$    |               |     |     | 60  | mA   |
| Power in SMF               | $P_o$       | $I_{op, max}$ | 2   | 3   |     | mW   |
| Center Wavelength          | $\lambda_c$ | $I_{op, max}$ | 620 | 635 | 650 | nm   |
| Bandwidth FWHM             |             | $I_{op, max}$ | 4   | 6   |     | nm   |
| Spectral ripple [RB=0.1nm] |             | $I_{op, max}$ |     | 0.2 | 0.4 | dB   |

#### 4. ABSOLUTE MAXIMUM RATINGS

Stresses beyond the absolute maximum ratings may cause permanent damage to the device. Exposure to absolute maximum rating conditions for extended periods may affect device reliability.

| Parameter                     | Symbol                           | Cond.       | Min  | Max | Unit   |
|-------------------------------|----------------------------------|-------------|------|-----|--------|
| Forward current               | $I_F$                            |             |      | 65  | mA     |
| Reverse voltage               | $V_R$                            |             |      | -2  | V      |
| Forward voltage               | $V_F$                            | $I_{F,max}$ |      | 3.0 | V      |
| Storage temperature           | $T_{stg}$                        |             | -40  | 85  | °C     |
| Operating temperature         | $T_{op}$                         | $I_{F,max}$ | -20  | 65  | °C     |
| Storage humidity              | $<30^{\circ}C$<br>$>30^{\circ}C$ |             | 5    | 95  | % r.h. |
| Thermoelectric cooler voltage | $V_{tec}$                        | **          |      | 4.0 | V      |
| Thermoelectric cooler current | $I_{tec}$                        | **          |      | 1.8 | A      |
| Thermistor Resistance         | $R_{th}$                         | 25°C        | 10   |     | KΩ     |
| Thermistor constant           | B                                |             | 3892 |     | K      |
| Lead soldering temperature    |                                  |             |      | 260 | °C     |
| Lead soldering duration       |                                  |             |      | 10  | s      |
| ESD                           |                                  | human b.m   |      | 500 | V      |

#### 4.1 ELECTRICAL TURN-ON CHARACTERISTICS

These devices are sensitive to current spikes or turn-on ramps with a fast rise-time. In order to operate the devices safely it is recommended that the electrical drive circuit has a rise time longer than 10uS and that a minimum 10uF capacitor is placed in parallel with the SLED as shown below.

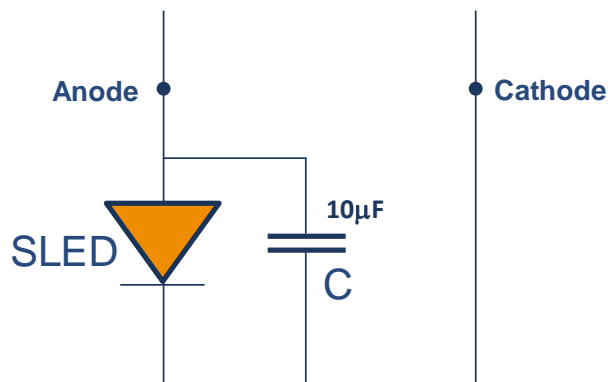

#### 5. SCREENING

The produced 635nm SLED Module is required to meet all operating conditions specified in Table 3, Electro-Optical Performance Specifications after being subjected to the following screening tests.

| Test Item           | Test Conditions   | Reference  |
|---------------------|---|--|
| Seal                | Fine: Condition A1<br>Gross: Condition C                  | MIL-STD-883, Method 1014<br>Temperature max 85°C |
| Temperature Cycling | -40°C to +85°C, ramp rate $\geq 5^{\circ}C/min$ 10 cycles | MIL-STD-883, Method 1010                         |



**6. PACKAGE DIMENSIONS [mm]**

**Tolerances :** .X ± 0.25 mm  
.XX ± 0.05 mm

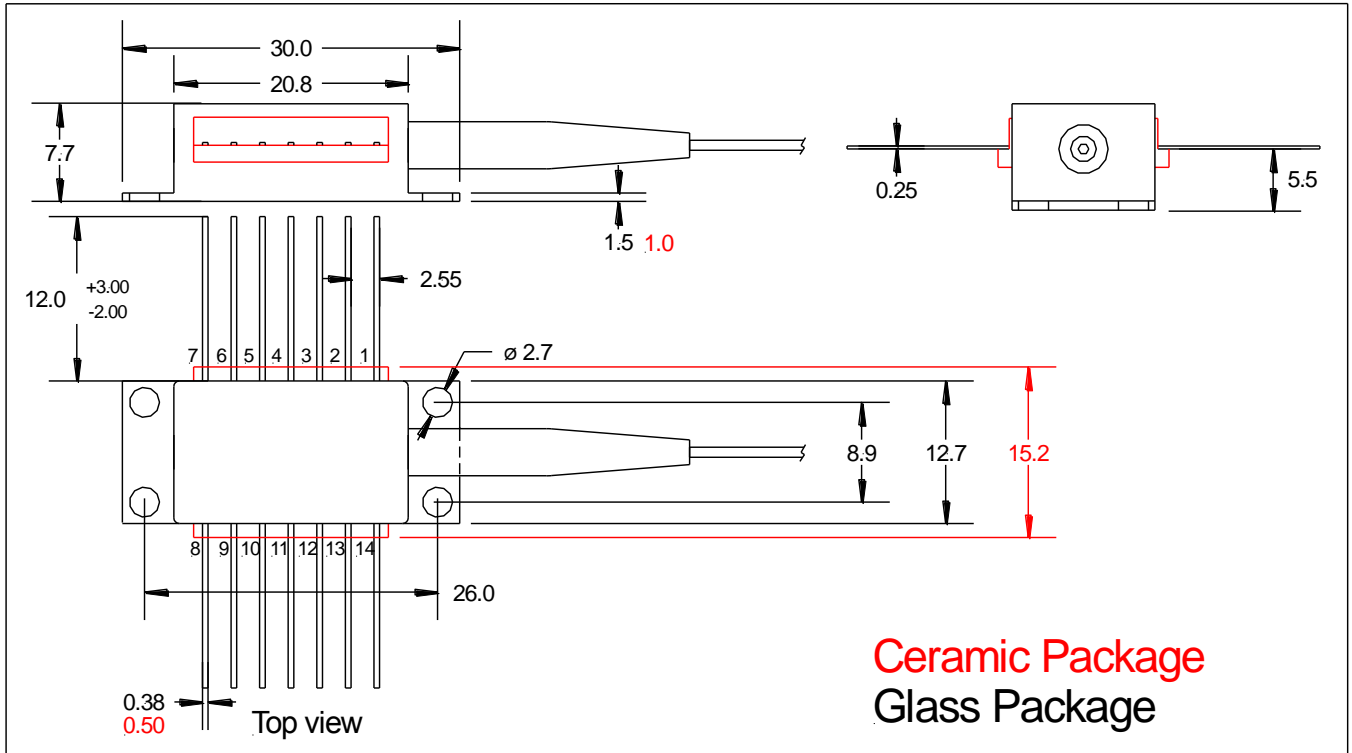

| Butterfly Package |            |     |                  |
|-------------------|------------|-----|------------------|
| Pin               | Function   | Pin | Function         |
| 1                 | TEC (+)    | 8   | NC               |
| 2                 | THERMISTOR | 9   | NC               |
| 3                 | NC         | 10  | SLED ANODE (+)   |
| 4                 | NC         | 11  | SLED CATHODE (-) |
| 5                 | THERMISTOR | 12  | NC               |
| 6                 | NC         | 13  | CASE GROUND      |
| 7                 | NC         | 14  | TEC (-)          |

**7. FIBRE AND CONNECTOR**

| Part                         | Description                           |
|------------------------------|---------------------------------------|
| SM Fibre                     | SM 3.3 / 125 µm Nufern <b>S405-XP</b> |
| Loose tube secondary coating | 900 µm                                |
| Fiber pigtail length [min]   | 1 m                                   |
| Optical connector            | FC/APC Narrow Key (2.0mm)             |

**8. IMPORTANT NOTES**

1. Avoid electrostatic discharges, which may destroy the SLED.
2. Never use the SLED module die without heat sinking.
3. Adequate eye protection against laser radiation should be used while handling and operating the module.
4. EXALOS declines any responsibility if the device is used in applications where human life may be endangered.
5. Back reflections may influence the output power and spectral characteristics of the SLED. The use of optical isolators and/or angled connectors is recommended. Back reflections of less than -30dB are recommended.

**9. ORDERING INFORMATION**

Please use the following **part number** to order product from EXALOS:

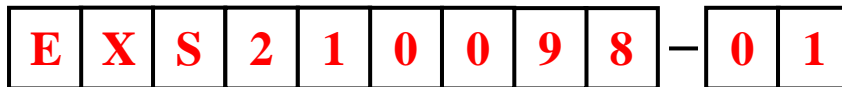

**9.1 TECHNICAL DESCRIPTION**

